

JAMES COOK CYCLONE STRUCTURAL TESTING STATION

CYCLONE TESTING STATION

EFFECTS OF CYCLONE WINIFRED ON BUILDINGS

TECHNICAL REPORT No. 27

August 1986

CYCLONE TESTING STATION

EFFECTS OF CYCLONE WINIFRED ON BUILDINGS

G.F. Reardon
G.R. Walker
E.D. Jancauskas

Technical Report No. 27

© James Cook Cyclone Structural Testing Station 1986

Reardon, G.F. (Gregory Frederick), 1937 - .
Effects of Cyclone Winifred on buildings.

ISBN 0 86443 214 3.

ISSN 0158-8338

1, Building, Stormproof - Queensland. 2. Cyclones -
Queensland. I. Walker, George R. (George Redvers),
1938 - . II. Jancauskas, E.D. (Erin Douglas).
III. James Cook University of North Queensland.
Cyclone Testing Station. IV. Title. (Series: Technical
report (James Cook University of North Queensland.
Cyclone Testing Station); no. 27.

EFFECTS OF CYCLONE WINIFRED ON BUILDINGS

G.F. Reardon*

G.R. Walker**

E.D. Jancauskas***

SYNOPSIS

Cyclone Winifred crossed the North Queensland coast near Innisfail late on the afternoon of 1 February 1986. It was the most damaging tropical cyclone to cross the Queensland coast since cyclone Althea in December 1971. Wind gusts of the order of 30 m/s or more were experienced over a front of about 150 km from Cairns to Cardwell. Maximum wind gusts are estimated to have been in the order of 50 m/s.

Damage to buildings was generally less than original estimates reported. With few exceptions newer houses built to current regulations suffered little damage. Older buildings often had roofing removed, frequently with battens still attached. Severe topographical features in the area are considered to have influenced wind patterns. Magnification of wind effects by escarpments appears to have caused significant damage.

The investigation indicated that more attention may need to be given to topographic effects, attachments such as roller doors, tilting doors, awnings and guttering, and corrosion of metal elements. Damage to school buildings was a matter of some concern in view of their frequent use as cyclone shelters in counter-disaster planning. Damage to shade cloth structures appeared to be serious enough to warrant more attention being given to wind resistance in their design.

* Technical Director, Cyclone Testing Station.

** Associate Professor, Department of Civil & Systems Engineering.

*** Lecturer, Department of Civil & Systems Engineering.

TABLE OF CONTENTS

	Page
1. Introduction	1.
2. Cyclone Characteristics	3.
2.1 Track and features	3.
2.2 Wind speeds	3.
2.2.1 Recorded data	3.
2.2.2 Wind speeds over the sea	7.
2.2.3 Wind speeds over land	10.
2.2.4 Estimation from building damage	12.
2.2.5 Analysis of road signs	14.
2.2.6 Conclusion	14.
2.3 Storm surge	14.
2.4 Classification of Winifred	16.
3. Modern Buildings	17.
3.1 General	17.
3.2 Structural failure	18.
3.2.1 Topographical effect	18.
3.2.2 Construction details	20.
3.3 Roof cladding failures	25.
3.3.1 Secret fixed cladding	25.
3.3.2 Corrosion	27.
3.4 Failure of non-structural elements	27.
4. Older Buildings	29.
4.1 General	29.
4.2 Structural failure of domestic buildings	29.
4.2.1 Topographical influences	29.
4.2.2 Construction	31.
4.2.3 Corrosion	33.
4.3 Structural failure of other buildings	34.
4.3.1 School buildings	34.
4.3.2 Agricultural or industrial buildings	34.
4.4 Cladding failures	36.
4.5 Flying debris	36.

	Page
5. Other Construction	39.
5.1 Shade cloth structures	39.
5.2 Caravans	40.
6. Conclusions	41.
7. Acknowledgements	42.
8. References	43.

1. INTRODUCTION

Cyclone Winifred crossed the North Queensland coast near Innisfail on Saturday February 1st, 1986. Estimates of damage indicate losses of the order of \$200 million, with damage to crops being the major loss. The area suffering significant damage stretched from Cairns to Cardwell, a distance of about 150 km. It was the most damaging tropical cyclone to make landfall in Queensland since cyclone Althea hit Townsville in December 1971. Cyclone Ted, which hit Burketown in 1976 may have been more severe (1), and cyclone Kerry which hit Mackay in 1979 may have been more severe while at sea (2), but neither produced the level of damage caused by Winifred.

In the fourteen year period between cyclones Althea and Winifred there has been a marked improvement in building standards. This is due in part to increased education of the building community, better inspections by local authorities and a greater awareness and responsibility by constructors, but mainly to the introduction in 1981 of the Queensland Home Building Code (3). Winifred was the first cyclone to put these building standards to the test. It was not as severe as the theoretical cyclone which is used as the design standard and it was to be expected, therefore, that new houses built to the provisions of the Code would have remained structurally intact. This proved to be the case, with very few exceptions. However it did highlight a number of significant factors which have tended to be overlooked in current practice.

Although this report deals primarily with the performance of buildings, the major damage caused by Winifred was to crops and vegetation. Cane fields and banana plantations were flattened, Figure 1, forests were stripped of leaves or burned dry by the wind and the rain forests were denuded of their canopy. The lighter areas on the hills shown in Figure 2 indicate wind burning of the forest. Early reports indicated that the cost of crop losses will far outweigh the cost of damage to buildings. Reports from Johnstone Shire, which includes Innisfail, estimate \$30 million associated with building damage and \$58 million from crop losses. An early report from Cardwell Shire estimated \$100 million primary industry losses. In May the Insurance Council of Australia estimated that damage caused by cyclone Winifred would cost the general insurance industry an estimated \$40 million.

Cyclone Winifred was accompanied by heavy rainfall. It resulted in local flooding in areas as far south as Ingham and caused the Bruce Highway to be closed for a few days. The heavy rain caused significant damage to the contents of many buildings. It also caused a large number of landslides in the steep hinterland of the region.

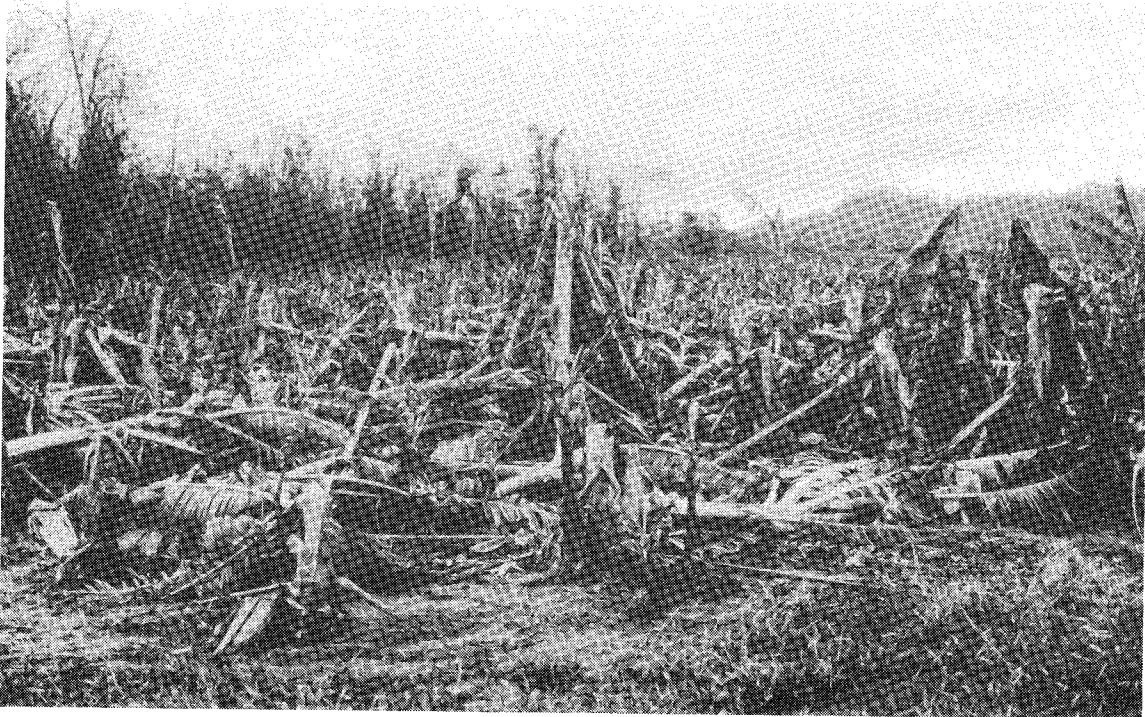

Figure 1. Banana Plantation Flattened



Figure 2. Wind-burnt Rain Forest

2. CYCLONE CHARACTERISTICS

2.1 Track and Features

Cyclone Winifred formed out of a tropical low approximately 450 km north of Cairns on 29 January 1986. After slowly moving roughly parallel to the coast to approximately 250 km ENE of Cairns it turned and moved in a southwesterly direction towards the coast late in the evening of 31 January 1986 (see Fig. 3). Winifred crossed the coast in the vicinity of Innisfail late in the afternoon of 1 February 1986. At that time Winifred had a central pressure of 957 mb and had been continuing to intensify. When it crossed the coast Winifred was travelling in a roughly westerly direction at a speed of approximately 15 km/h and had an unusually large eye of the order of 50 km in diameter stretching from just north of Innisfail to around Mission Beach (see Fig. 4). As it crossed the coast the eye decreased in size and does not appear to have persisted more than 60 km inland.

2.2 Wind Speeds

2.2.1 Recorded data

The nearest anemometer operated by the Bureau of Meteorology was at Cairns which was too far from the centre of Winifred to be of much use in determining wind speeds in its vicinity. Fortunately however the Department of Defence has an anemometer at Cowley Beach which was within the eye of the cyclone as it crossed the coast and just south of its centre. This anemometer remained operational throughout the passage of the cyclone and provided a very good record of the wind speed characteristics of Winifred as it crossed the coast.

The Cowley Beach instrument is a synchrotac anemometer and gives ten minute mean wind speeds for successive ten minute periods throughout the day as well as the instantaneous wind direction every ten minutes. Plots of the recorded wind speeds and wind directions are shown in Figure 5.

The anemometer is located approximately 18 m inland from the beach at a height of 10 m in flat open terrain. From south through east to northeast, the directions from which the wind was primarily blowing during the passage of Winifred, the fetch is over the sea. From the other directions, with the exception of southsouthwest to west, the fetch is over at least 5 km of flat scrub covered land.

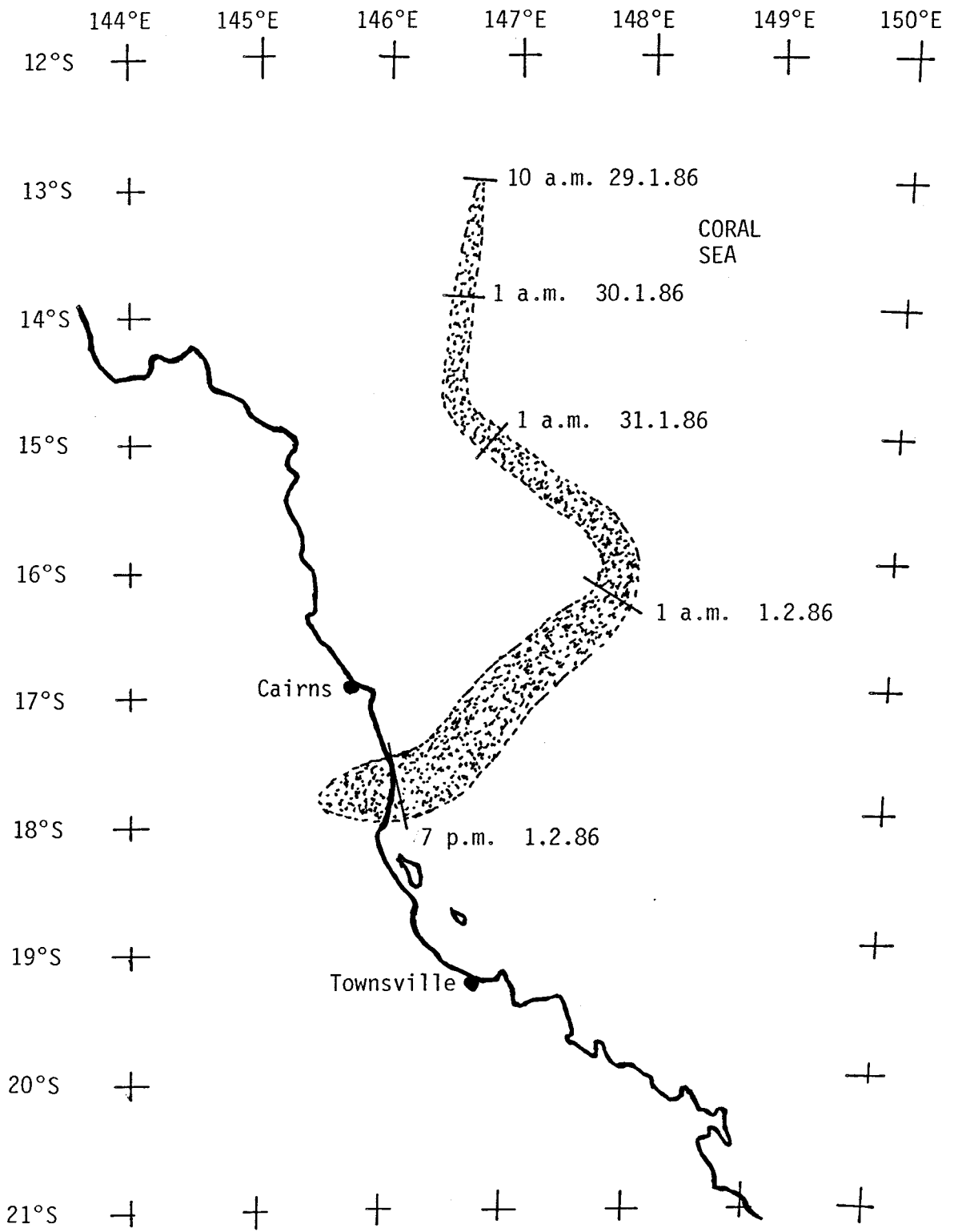

Figure 3 Approximate Track of Cyclone Winifred.
(Based on information supplied by Bureau of Meteorology)

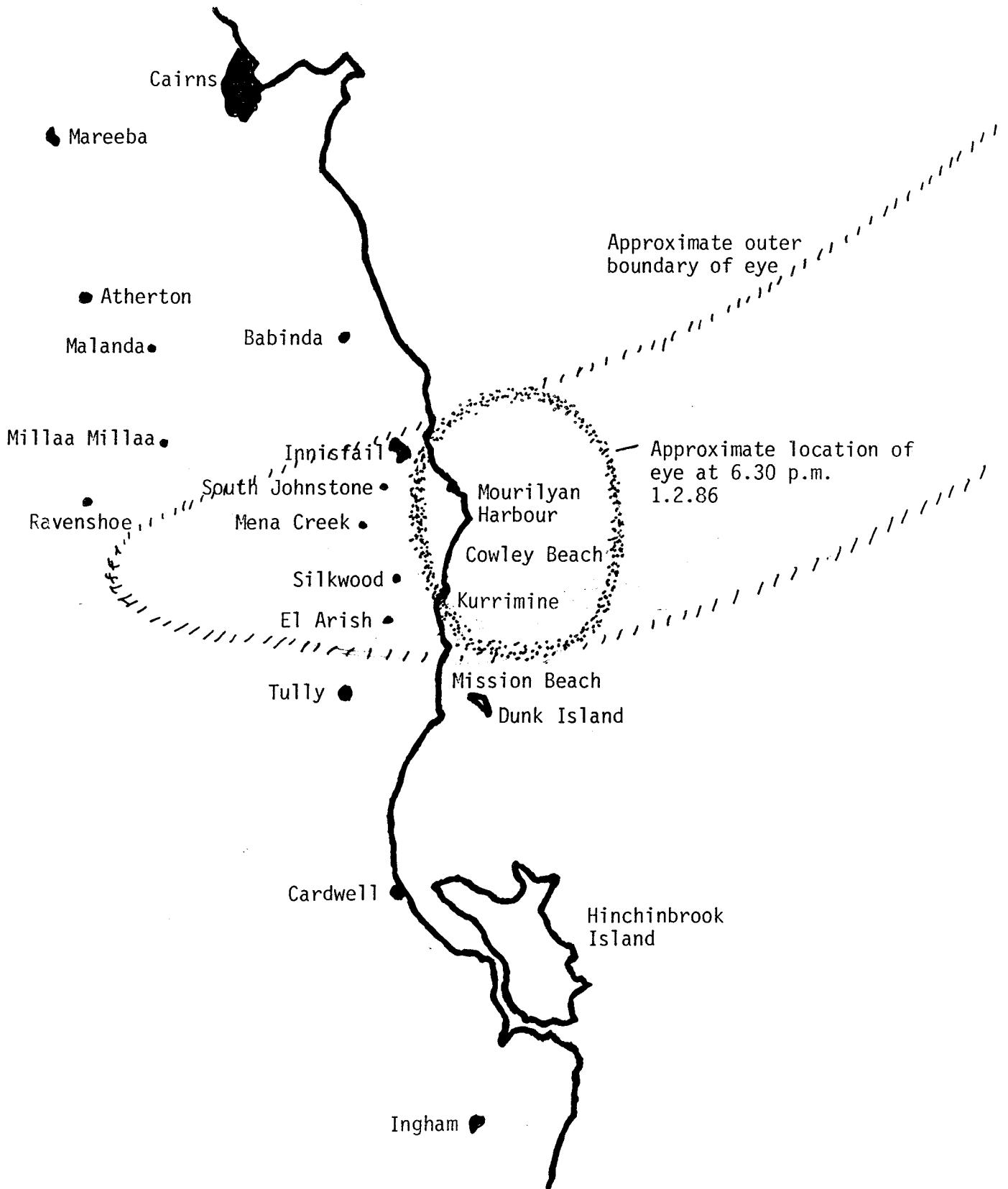

Figure 4 Location of Cyclone Winifred as it crossed the coast

CYCLONE WINIFRED - COWLEY BEACH

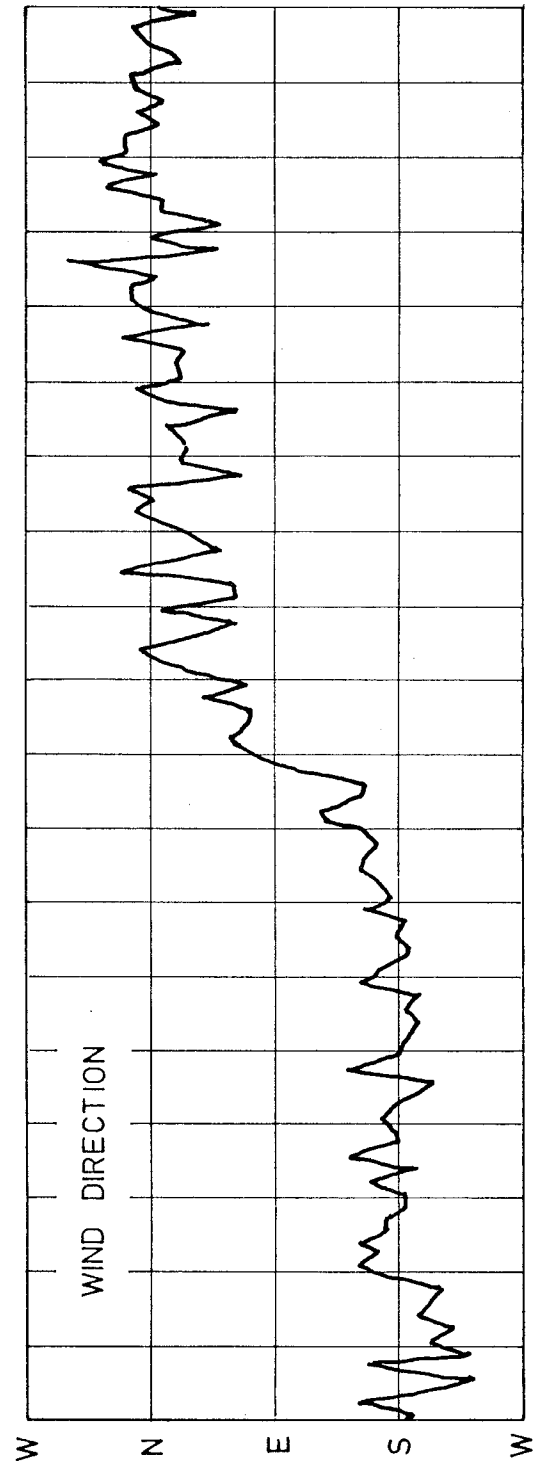
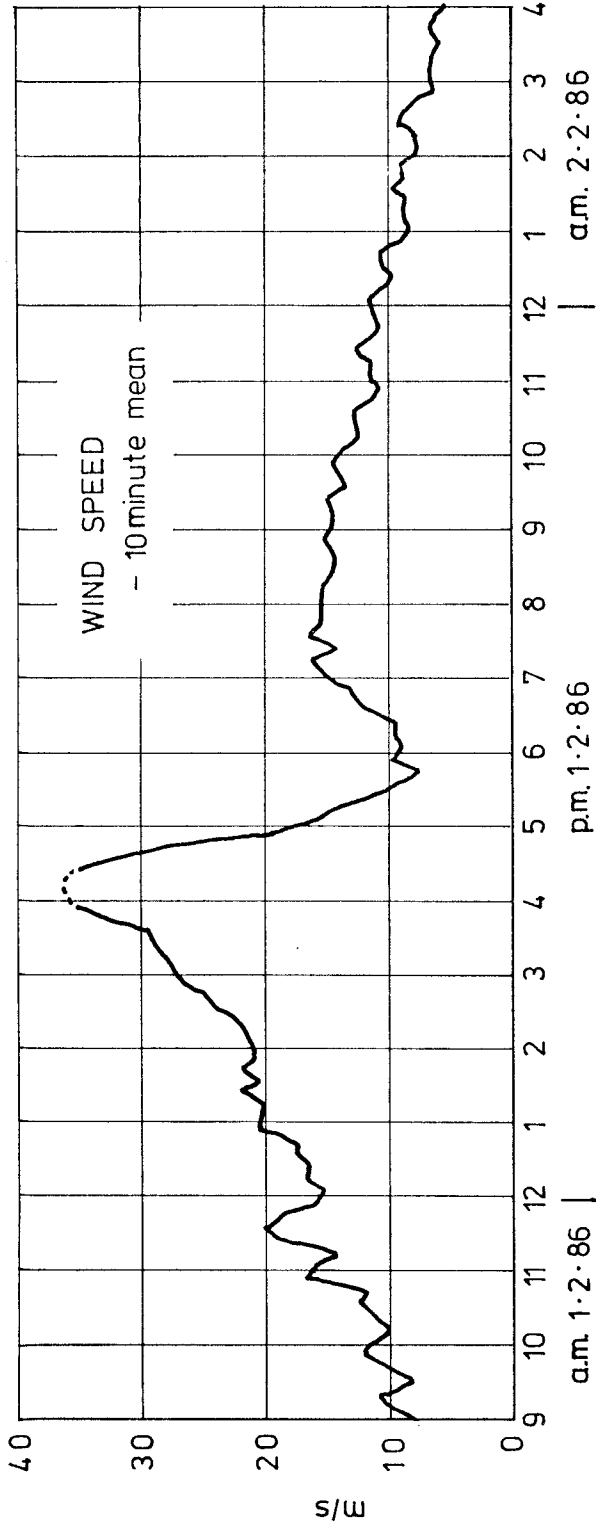

Figure 5 Wind Records Obtained at Cowley Beach During Cyclone Winifred

Unfortunately due to limitations in the instrument's recording system there is a question mark regarding the reliability of the three maximum wind speed readings. However comparison with past records of wind speeds near the centre of tropical cyclones suggest that the indicated values are close to the actual values that occurred. On the basis of this record it appears reasonable to assign a maximum ten minute mean wind speed at 10 m height of 35 m/s at Cowley Beach.

The sharp drop in wind speed after 4.30 pm indicates the arrival of the eye. The much lower wind speeds recorded following the passage of the eye suggest that by this time with the centre of the eye 20 - 30 km inland and the leading edge of the eye 40 - 50 km inland Winifred had weakened considerably in intensity.

The jagged nature of the plot of wind directions reflects the effect of turbulence on instantaneous wind direction. The smoothed curve through the points is a more realistic description of the ten minute mean wind directions. The change in direction from south as the cyclone approached through east to north northeast as the cyclone passed over is consistent with the location of the anemometer being slightly south of the path of the centre of the eye.

2.2.2 Wind speeds over the sea

The wind speed at a particular location and time during a tropical cyclone is a function of the central pressure, the radius of maximum winds, the forward speed of the cyclone, location relative to the centre of the eye, the surface terrain, the height above the surface, latitude, topography and other meteorological factors. A number of mathematical models of varying complexity have been developed to describe the wind field. These are generally only strictly applicable over the sea because of the complications arising from the weakening in intensity once cyclones cross the coast and from the influence of topography. They are mostly semi-empirical in nature and based on fitting observed data from previous tropical cyclones. The wind speed is normally made up of two components - one arising from the rotating nature of the cyclone and the other from the forward speed of the cyclone. Examples of these are to be found in Graham and Nunn (4), Martin (5), Atkinson and Holliday (6), Gomes and Vickery (7), Tryggvason (8) and Georgiou, Davenport and Vickery (9).

For determining the pattern of maximum ten minute mean wind speeds over the sea at a height of 10 m the following formulae can be shown to be a reasonable approximation in the southern hemisphere:

Along the track of the centre of the eye:

$$V = C \sqrt{p_c - 1010} \cdot \left(\frac{R}{r}\right)^k$$

To the left of the track of the eye:

$$V = C \sqrt{p_c - 1010} \cdot \left(\frac{R}{r}\right)^k + 0.5 V_s$$

To the right of the track of the eye:

$$V = C \sqrt{p_c - 1010} \cdot \left(\frac{R}{r}\right)^k - 0.5 V_s$$

where

- V = maximum ten minute mean wind speed (m/s)
- p_c = central pressure (mb)
- r = distance from track of centre of cyclone (km)
- R = radius of maximum winds (km)
- V_s = forward speed of cyclone (m/s)
- C, k = constants obtained by fitting to cyclone data

For Winifred, C and k can be determined from the Cowley Beach record, since it was close enough to the centre of the cyclone for the maximum recorded wind speed of 35 m/s to be assumed as the maximum wind speed along the track when the central pressure was 957 mb. The plot of increasing wind speed as Winifred approached could then be used to evaluate k, assuming a steady forward speed of approach of the order of 15 m/s. This gives as a reasonable approximation C = 4.8 and k = 0.67. Using these constants in the above formulae in conjunction with information supplied by the Bureau of Meteorology on central pressure along the track as Winifred approached the coast, the wind field map shown in Figure 6 was obtained.

While ten minute mean wind speeds are the most relevant in relation to the sea state and effects related to this, wind effects on structures are more a function of the maximum wind gust speeds. In Australia for instance wind loading criteria for building design is related to the maximum expected three second gust speed. The relationship between the maximum ten minute mean wind speed and the maximum three second wind gust speed at the same location depends on the turbulent characteristics of the wind (10). For steady wind over the sea these change with wind speed due to the increasing roughness of the sea as wind speeds increase. For the range of interest of a ratio of 1.4 is commonly

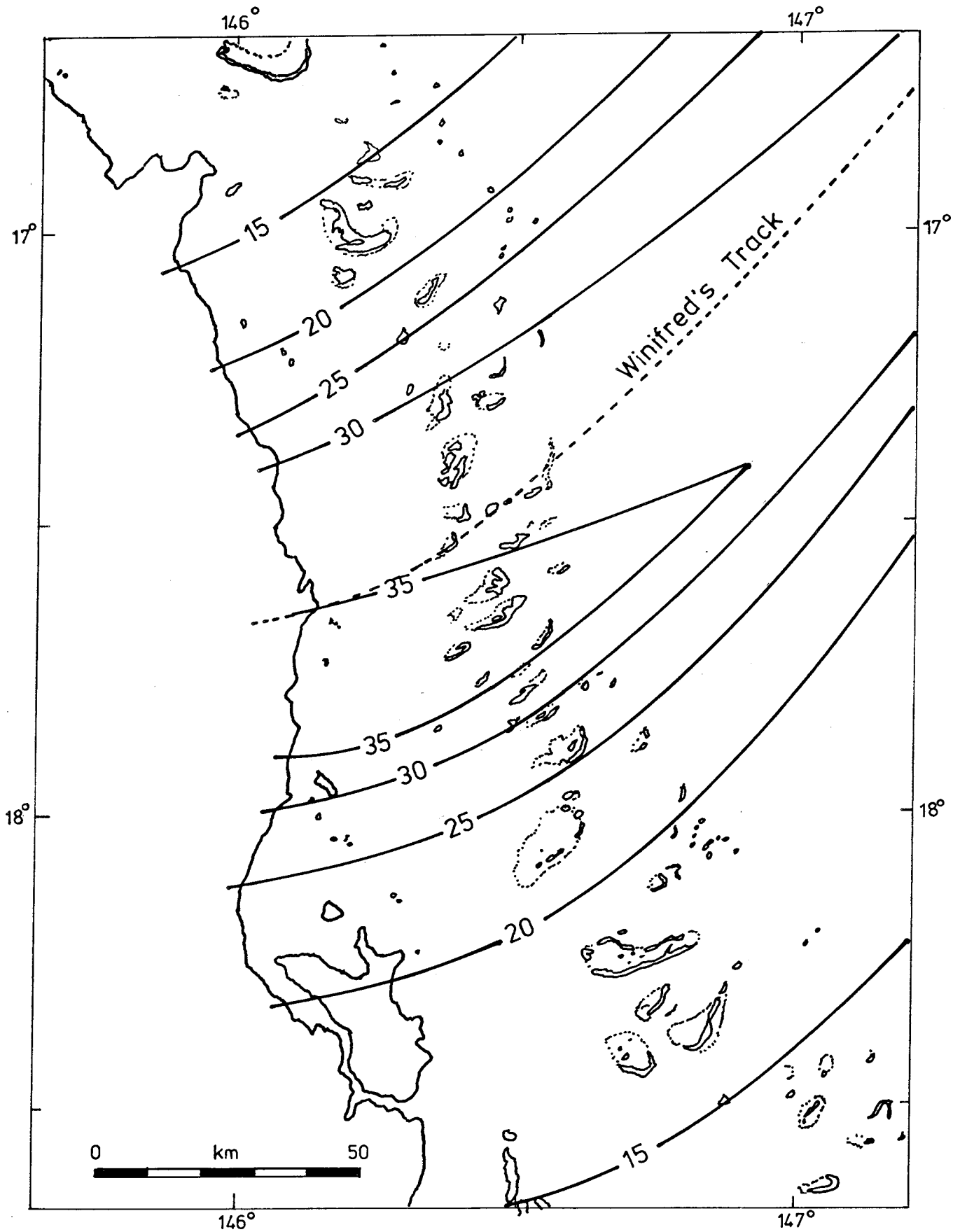

Figure 6 Map of Estimated Maximum 10 Minute Mean Windspeeds Over the Great Barrier Reef Area During Winifred.

assumed but studies by Melbourne (11) of wind records obtained in Hong Kong during typhoons suggest that this may underestimate the gust speeds in the region of maximum winds with ratios between 1.4 and 1.5 being relatively common. The increased turbulence giving rise to these higher values may be due to wind shears within the cyclone. For wind off the land significantly higher gust ratios could be obtained particularly if the terrain is very rough.

2.2.3 Wind speeds over land

Over land it is the wind gusts that generally cause the problems rather than the mean wind speeds. The discussion in this section will therefore be in terms of the maximum three second gust speed at 10 m height over flat open terrain, this being the standard reference for expressing wind speeds by the Bureau of Meteorology and for building design standards.

If the land was flat and featureless it could be assumed that the wind field over the land would be very similar to the wind field over the sea until the eye crossed the coast and would then contract as the cyclone weakened as it moved inland. Even if no information was available on the weakening after crossing the coast this approach would be expected to at least give a good indication of wind speeds near the coast before the cyclone weakened.

However rarely is the land flat and featureless and cyclone Winifred highlighted how misleading this approach can be when the topography is very rough as it is in North Queensland. Figure 7 shows the pattern of estimated maximum gust speeds based on a gust ratio of 1.45 just prior to Winifred crossing the coast. Apart from near the centre of the cyclone the pattern of building damage and the measured wind speeds at Cairns indicate this is a poor representation of the actual wind gust speeds that occurred in Winifred. The reason for this is believed to be the very rugged topography of the area.

Figure 7 suggests that the highest wind speeds would have been experienced in the Kurrimine Beach to Bingil Bay area with maximum wind gusts between 50 and 55 m/s occurring, which is consistent with observed wind damage. Away from this area however there are many inconsistencies. For instance Figure 7 suggests that Tully and Innisfail should have experienced similar wind speeds with maximum wind gusts between 45 and 50 m/s and Babinda and Cardwell much less with maximum wind gusts of the order of 35 m/s and 30 m/s respectively. Yet observations of wind damage suggest that while the wind speeds in Innisfail may have agreed with this estimate, the wind speeds in Tully were much less than in Innisfail, the wind speeds in Babinda were similar to those experienced in Innisfail, and the wind speeds in Cardwell were less than would have been expected from this analysis.

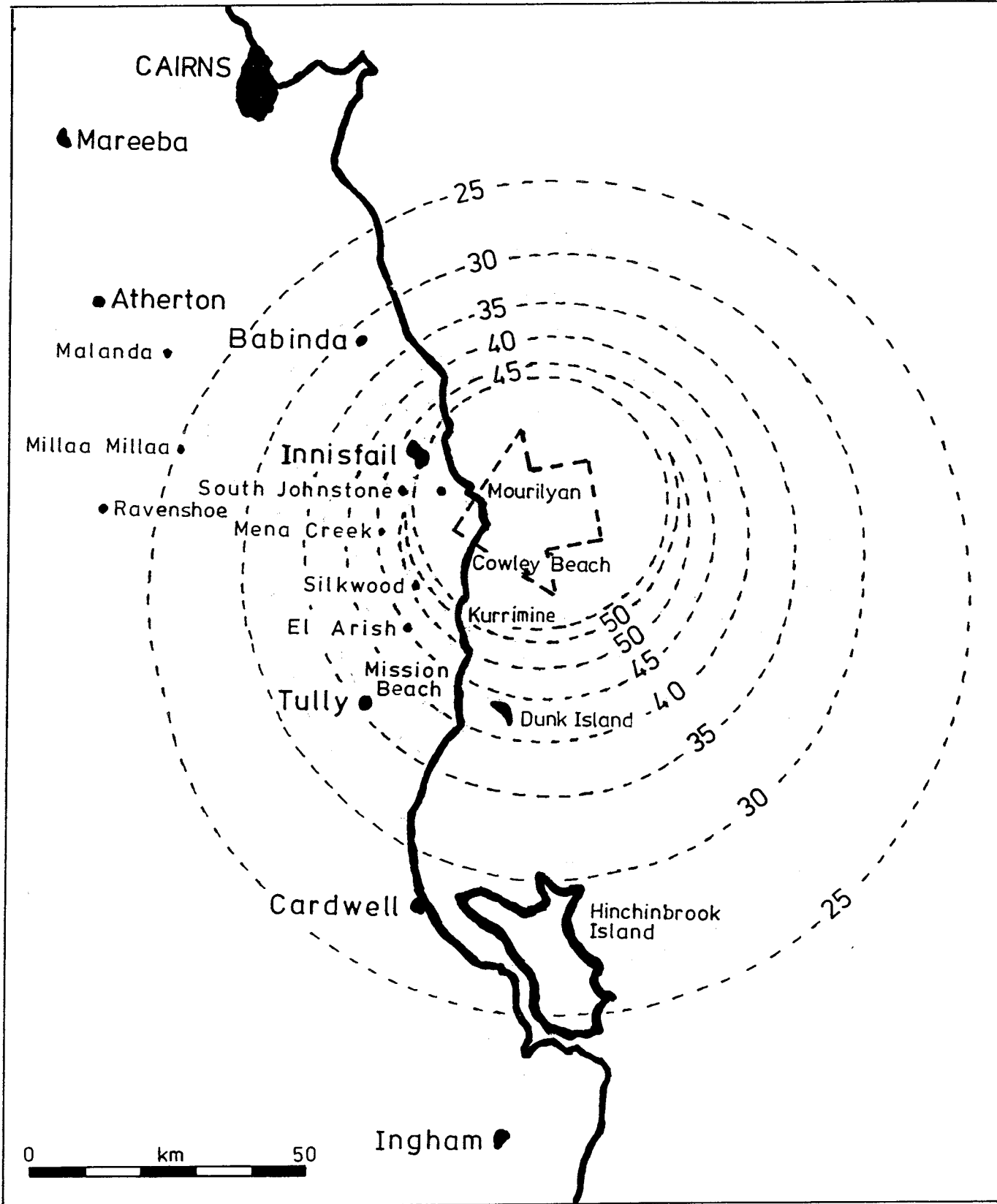

Figure 7 Postulated Maximum Gust Speeds as Winifred Approached Land. Based on Cyclone Windspeed Model Over the Sea.

The overall impression was that on land wind speeds to the north were greater than those to the south contradicting the normally held view of wind fields in tropical cyclones. Topographical sheltering in the case of Tully and Cardwell, and topographical funnelling in the case of Babinda were probably major factors in these anomalies. High levels of turbulence generated by wind flow over the rugged topography causing high gust speeds even if mean wind speeds were relatively low was probably a significant factor in amplifying the gust speeds in general to the north of Winifred's path.

The wind records obtained at Cairns by the Bureau of Meteorology highlight the effect that topography can have on wind speed patterns. The Bureau operates two anemometers at Cairns Airport approximately a kilometre apart. Figure 8 shows the two wind speed records obtained from these during Winifred. The most striking feature is the difference between the two records. One measured a maximum wind gust of 33 m/s at about 7.15 p.m. and the other a maximum of 29 m/s over an hour later, and the shape of the two records is quite different. The difference is believed to be due to the close proximity of a large hill, with the highest reading being obtained from the anemometer closest to the hill due to local acceleration of wind around the edge of the hill. It will also be noticed that both the maximums are well above the expected value based on Figure 7. However closer inspection will show that the mean wind speeds were at all times less than 15 m/s which is consistent with Figure 6 and indicates that it is high gust ratios in excess of 2 due to very high levels of turbulence that are the principal reasons for the high maximum gust speeds, again highlighting the significance of topographic effects on wind speeds over land.

2.2.4 Estimation from building damage

In a preliminary report on cyclone Winifred (12) it was estimated that peak gusts at 10 m height in category 2 terrain were probably in the range of 47-53 m/s. This estimate was primarily based on a comparison of damage to older houses with damage to similar houses in Townsville during cyclone Althea. The maximum recorded gust during Althea was 55 m/s. The intensity of damage to older buildings in the Innisfail to Mission Beach area appeared to be slightly less than occurred in Townsville to similar buildings in similar conditions of exposure.

The study of building damage from Winifred suggests that wind speeds to the south of the eye appeared to be much less than was estimated in the previous section, wind speeds in the path of the eye a little less, and wind speeds to the north of the same order or greater. The latter was confirmed by the measured peak wind speed of 33 m/s in Cairns.

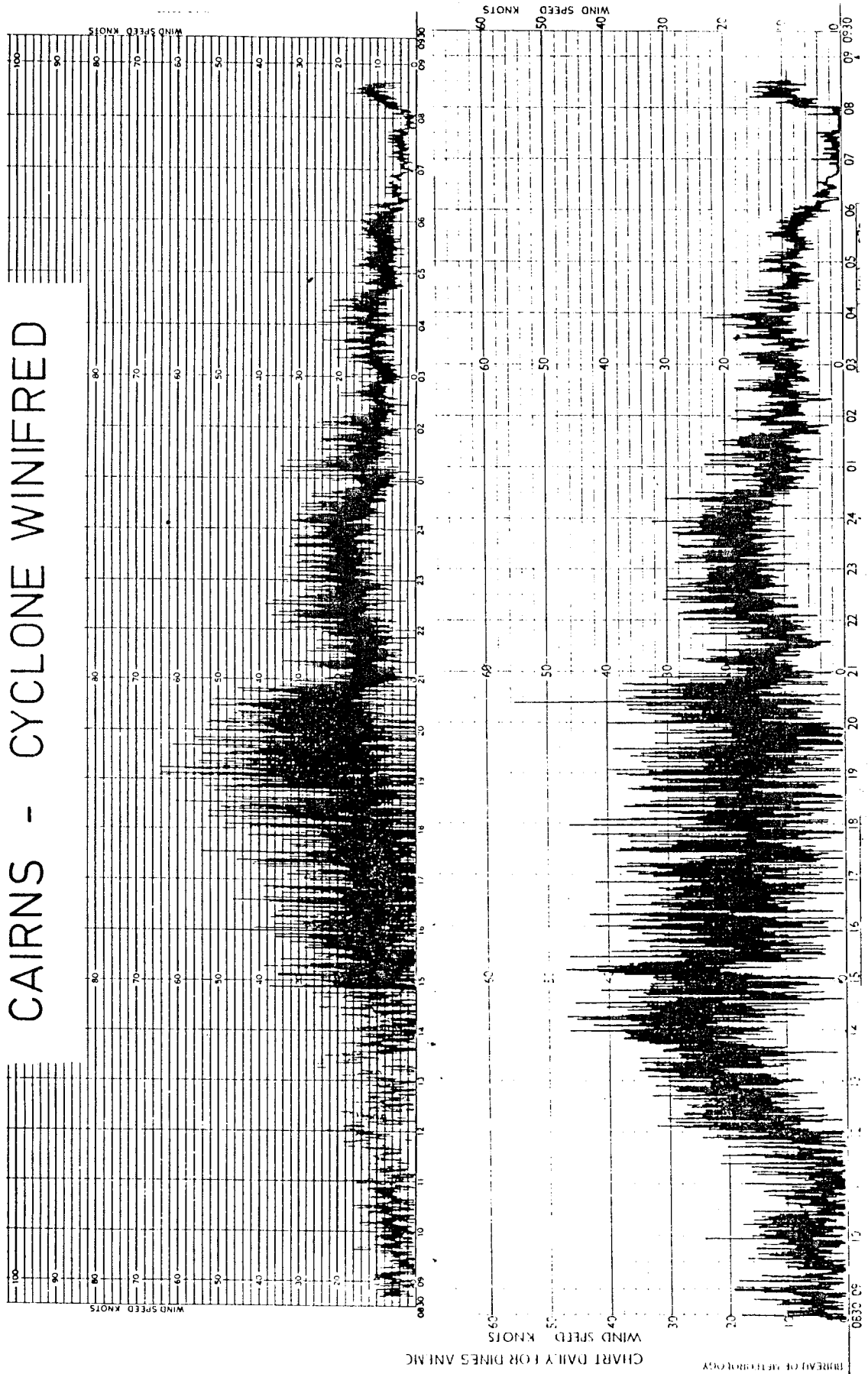

Figure 8 Records of Windspeed Obtained at Cairns Airport During Cyclone Winifred.

However, such comparisons have their limitations as construction details often vary from one locality to another, and improvements in roof cladding fixings since Althea have probably been fairly common. The latter will probably have increased the threshold wind speed at which roof damage is likely to be initiated. This is of course a very subjective method of assessment, and relies heavily on the experience of the observer.

2.2.5 Analysis of road signs

A preliminary analysis of the performance of road signs in cyclone Winifred, Figure 9, indicates maximum wind speeds greater than 45 m/s and less than 65 m/s in the Innisfail-Mourilyan area. Only unbraced pole supported signs which were either undamaged, or had failed by bending of the supporting poles at ground level were considered. Failed systems showing any evidence of having been hit by debris were excluded.

As with the other approaches, there are many uncertainties associated with the analysis of road signs. In addition to assumptions about exposure, wind direction, wind structure (for extrapolating to 10 m height) and material properties, there are also questions about dynamic response and the possibility of local buckling rather than plastic yielding initiating failure. These latter factors are the subject of studies currently being undertaken at James Cook University. Because of the relatively large difference in strength between those that failed and those that survived, with one exception - and other factors could account for that - this method is relatively imprecise for defining the maximum wind speed, but the range is consistent with maximum wind gusts of the order of 50 m/s.

2.2.6 Conclusion

On the basis of the above studies it seems probable that maximum wind speeds in the region were between 50 and 55 m/s. This is a little higher than originally assessed on the basis of wind damage alone and suggests that improvements in cladding fastening in older buildings may have increased their damage threshold wind speed. (Although it is still much less than required by current criteria.)

2.3 Storm Surge

A storm surge of the order of 2 m appears to have accompanied Winifred. However, like Althea, the cyclone crossed at approximately low tide, so that little coastal inundation occurred. Damage attributed to storm surge effects



Figure 9. Road Sign Bent by Wind Forces



Figure 10. Beach Erosion Caused by Storm Surge

was minimal, being generally restricted to beach erosion, Figure 10. This fortunate occurrence should not be allowed to lead to a reduction of the public perception of the risk from storm surge. A cyclone crossing coincident with high tide poses a severe threat to the coastal communities, and the recommended evacuation of low lying coastal areas during Winifred was certainly justified.

2.4 Classification of Winifred

On the international five point Saffir Simpson Scale - see Table 1 - Winifred would be classed as a severe cyclone of intensity 3 as far as central pressure and wind speeds are concerned. By comparison cyclone Tracy which hit Darwin in 1974 and the 1918 Innisfail cyclone were very severe cyclones of intensity 4. Cyclone Althea was intensity 3. Catastrophic cyclones of intensity 5 are very rare. The most well known example of a cyclone of this intensity is Hurricane Camille which hit the southern coast of the United States in 1969.

TABLE 1

INTENSITY SCALE OF TROPICAL CYCLONES

Magnitude	Saffir Simpson Scale	Central Pressure (mb)	Maximum Wind Gust		Maximum Storm Surge (m)
			(knots)	m/s	
Mild	1	>990	40-60	20-30	0-1
Moderate	2	970-985	70-90	35-45	1.5-2.5
Severe	3	950-965	100-120	50-60	3-4
Very Severe	4	930-945	130-150	65-75	4.5-5.5
Catastrophic	5	<925	160-180	80-90	6-7

On average an intensity 3 cyclone or greater can be expected to cross the coast between Port Douglas and Mackay every ten to fifteen years, with any particular location experiencing one on average every thirty to fifty years. An intensity 4 cyclone can probably be expected in this region on average every 50-70 years.

It must be emphasised that the relationships between central pressure, maximum wind speed and maximum storm surge height are only approximate and that many cyclones do not fit this pattern. For instance cyclone Tracy was only an intensity 3 cyclone in terms of central pressure and storm surge, but an intensity 4 cyclone in terms of wind speeds. Winifred was apparently only an intensity 2 cyclone in terms of storm surge, although it was an intensity 3 cyclone in terms of wind and central pressure.

3. MODERN BUILDINGS

3.1 General

Building damage was in general much less than originally reported in the media. It is estimated that less than 5% of all the houses in the area affected by Winifred would have had significant damage, but a more accurate figure should be available when insurance statistics have been analysed. Damage appeared less in proportional terms than occurred in Townsville during cyclone Althea. This can be attributed to improvements in the fastening of the roof cladding of older buildings undertaken since Althea and the much better performance of houses built in accordance with the new cyclone resistant building regulations. These were introduced progressively following cyclones Althea and Tracy and formalised in 1982 with the adoption of the Home Building Code Queensland as Appendix 4 to the Queensland Building By-Laws.

In the context of this report the term "modern buildings" will include buildings up to five years old. For houses, the definition would include all that have been built since the introduction of Appendix 4.

An obvious example of the difference in performance of modern and older houses was evident at Kurrimine Beach where, within approximately one kilometre, there are a group of houses 15 to 20 years old and another group of modern houses. It is estimated that significant damage occurred to 20-30% of those older houses whereas the modern ones had damage restricted to failure of attachments such as guttering, awnings etc. - i.e. structural damage to the main fabric of the houses was almost non-existent. Although undamaged, many new houses suffered contents damage due to rain water entry through door and window surrounds.

The object of current building regulations is to minimise damage in the event of an intensity 4 cyclone. All buildings built to these standards should have safely withstood Winifred without any sign of distress, unless hit by wind borne debris or falling trees. The excellent performance overall of these

buildings suggests that the effort and expense that has been expended in developing and implementing these new regulations has been justified. The extension of these requirements to attachments and minor structures (such as garden sheds) to reduce wind borne debris, which would be much more potent in an intensity 4 cyclone, would seem to be justified. It would also appear that more attention needs to be given to the design of houses in very exposed locations. A wind tunnel investigation of the increased wind loads on houses situated on escarpments has already been commenced at James Cook University. Current regulations do not require doors and windows to be designed to resist rain penetration in a cyclone. This may need to be reviewed.

3.2 Structural Failure

Only two modern houses were observed to have failed structurally. In each case there was a specific aspect to which the failure could be related. One of the houses was located at Coquette Point, at the mouth of the Johnstone River, where the wind speed would have been significantly increased by local topographical features. The other house was in suburban Innisfail but apparently had a construction deficiency which led to structural failure.

3.2.1 Topographical effect

Coquette Point consists of a ridge with steeply rising sides. Figure 11 shows a view from the ridge, virtually at the location of the damaged house. The height of the ridge at that position is approximately 70 metres.

The house lost part of its roof and walls, Figure 12. A detailed examination of the building could not be made as it was partly covered with tarpaulins, the debris had been cleaned up and the owner was away. It was apparent that much of the roofing and battens had blown off and some walls had collapsed. Two reinforced concrete block columns that were part of the front wall structure had also been blown over.

One unusual mode of failure in this house was the longitudinal splitting of some exposed rafter members, Figure 13. It is not clear how the battens were attached to the rafters, but they were probably either nailed or fastened with framing anchors. The longitudinal splitting would have been caused by the uplift pressure on the roofing and failure of the timber by tension stresses acting perpendicular to the grain. The timber was probably imported Douglas fir (oregon).



Figure 11. View From Coquette Point Ridge

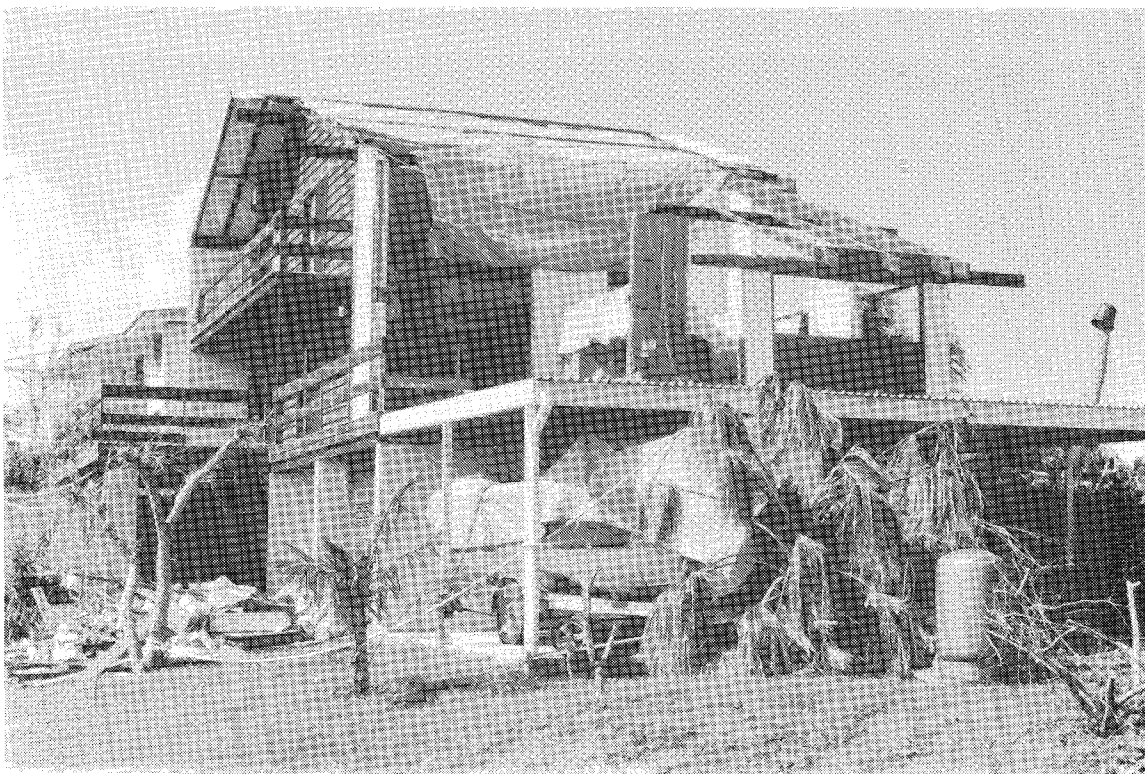

Figure 12. Roof and Wall Damage to Modern House

Using the current Wind Loading Code (13), a maximum design wind speed of 85 m/s can be calculated for Coquette Point. This value, based on category 1 approach along the river, would extend for some 70 m back from the crest and values above 80 m/s would apply for a similar length in front of the crest. Proposals to be included in the Limit State edition of the code would result in a maximum design wind speed of 100 m/s at the crest of the Coquette Point ridge and about 82 m/s at 100 m away from the crest. It is unlikely that the house would have been designed for wind speeds of 85 m/s or more.

Using the proposals for the limit state code, a maximum wind gust of 79 m/s can be calculated for Coquette Point during Winifred, based on the estimated 50 m/s for Innisfail.

The situation of houses on ridges or escarpments, where the wind accelerates over the top, can cause a problem in respect of engineering design. Forces calculated for a design wind speed of 85 m/s at Coquette Point (or any other similar location) are 80% greater than those calculated for the normal exposed location wind speed of 63 m/s (terrain category 1, 6 m height). Therefore the structural frame and other components of the house must be individually designed to cope with these forces. Pressures on claddings, glazing, fixings, and other elements will be significantly higher than would be covered by manufacturers' recommendations. To further compound the problem, extrapolation of existing data may not be satisfactory especially for materials affected by the fatigue loading that occurs during a tropical cyclone.

3.2.2 Construction details

Figure 14 shows a damaged house in suburban Innisfail. As it was the only house severely damaged in that general location, its construction details were questioned. The house was a kit home, reportedly assembled by a builder. Its basic components were wall panels approximately one metre long, graded purlin roof construction and continuous roof decking. All the elements were made from light gauge steel and bolted together. The ribbed roofing was fastened with screws and cyclone washers at every rib. Usually the components of such houses are engineer designed.

From a brief inspection it appeared that the failure was initiated by the purlin lifting off the verandah posts. This failure then severely overloaded the bolts holding down the next purlin and progressive failure occurred at each purlin. Figure 15 shows a purlin hold down detail through which the bolts had burst. After the purlin supporting the front wall was lifted, the wall collapsed laterally and the ceiling panels fell in. There was no obvious evidence of the roof sheeting coming away from the purlins.

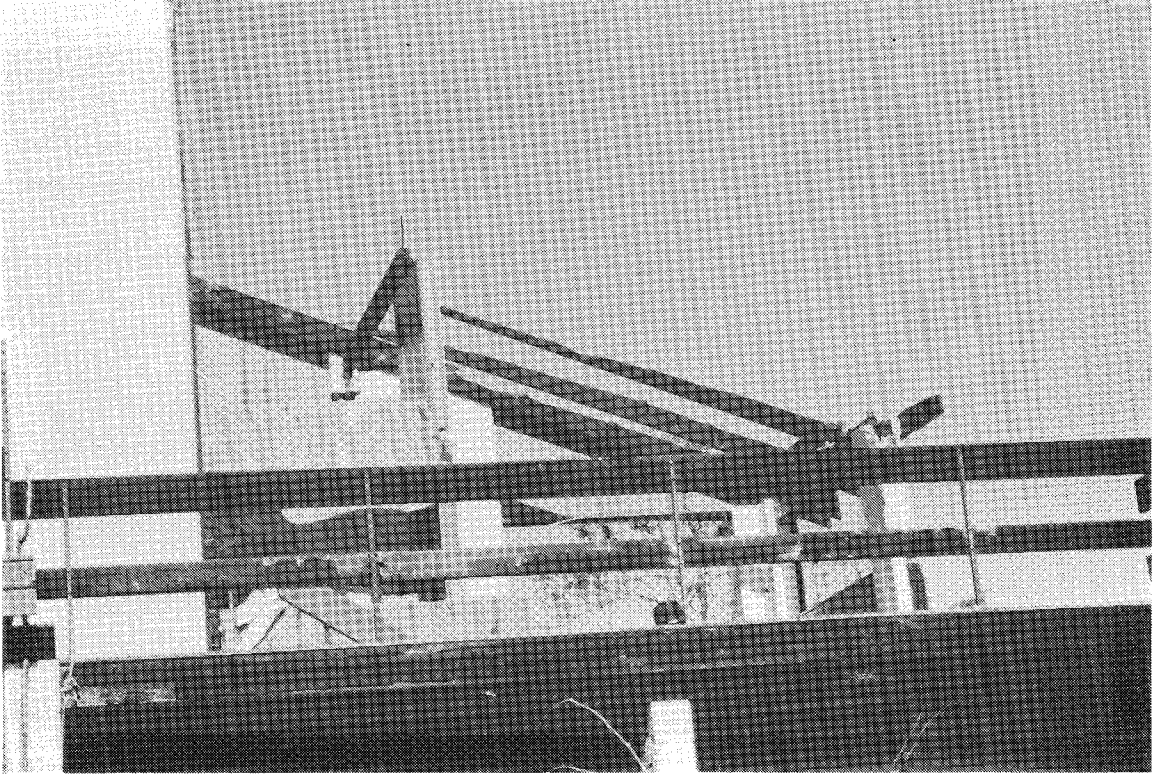

Figure 13. Splitting of Exposed Rafters



Figure 14. Damage to Panelized House

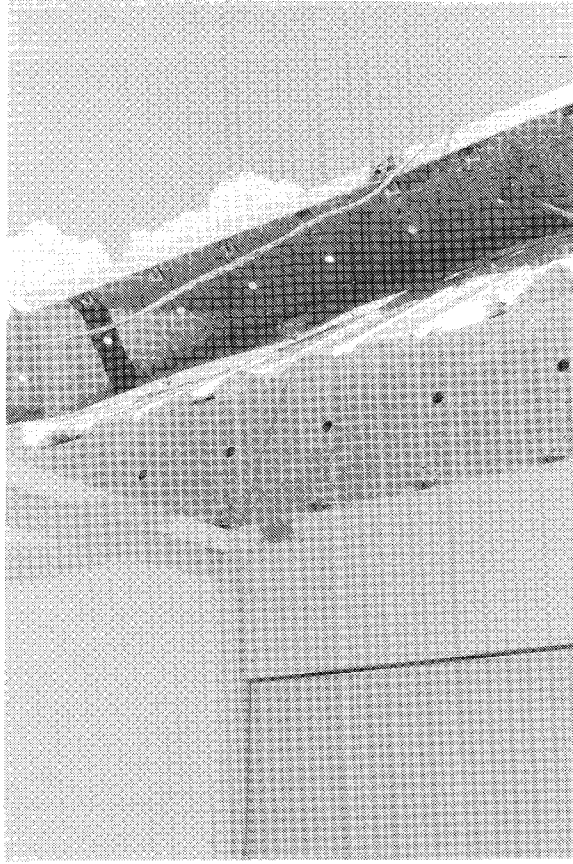

Figure 15. Bolts had Burst Through Purlin Attachment



Figure 16. Damaged Roll-away Doors

The current owner of the house maintained that undersized bolts had been incorrectly used to secure the purlin to the verandah posts and that they had pulled through the comparatively oversized holes.

It was noted that the graded purlins had been fabricated in two lengths and spot welded together, possibly on site. (All joints were in the same alignment, which is not good practice.) Most of the welds that were visible had broken, but this may have been a result of the roof lifting rather than a contributing cause of failure.

The home was located in suburban Innisfail and the approach direction of the wind was over typical category 3 terrain. However the house was of high set construction among predominantly low set ones in the wind's approach path. Further the presence of the Johnstone River some 350 m wide and about 250 m from the house would have affected the wind speed.

The effect of the gap in terrain category 3 caused by the river can be calculated as increasing the pressures on the house by about 10%. The effect of the protruding high set house is not as easily calculated although, based on experience from other storm damage investigations, it is considered unlikely that the effect would have been a major factor in the poor performance of the house.

A relatively new printery in South Innisfail represented the concept of a commercial building using domestic construction techniques. It was of reinforced blockwork construction with a timber trussed roof. The trusses were secured by bolting to overbattens. Access for inspection was unavailable but it appeared that the overbattens broke at the bolts allowing some trusses to lift off the building. No details of the building were taken for a structural analysis of the forces in the overbatten, but it was concluded that sound principles of domestic construction had been extended too far in this instance. It should be noted that members of another investigating team expressed concern that the timber overbattens in this building had decayed or otherwise deteriorated, possibly initiating the failure.

Although no structural damage to well designed commercial or industrial buildings was observed, there were frequent reports of damage to large doors. Figure 16 shows a bad example of the performance of roll-away doors. There were at least seven roll-away doors in this building and six were damaged as shown. The damage was not restricted to rolling doors; similar reports were made about doors using a tilting mechanism to open and close. There is an obvious need for improvement in the performance of these types of door.

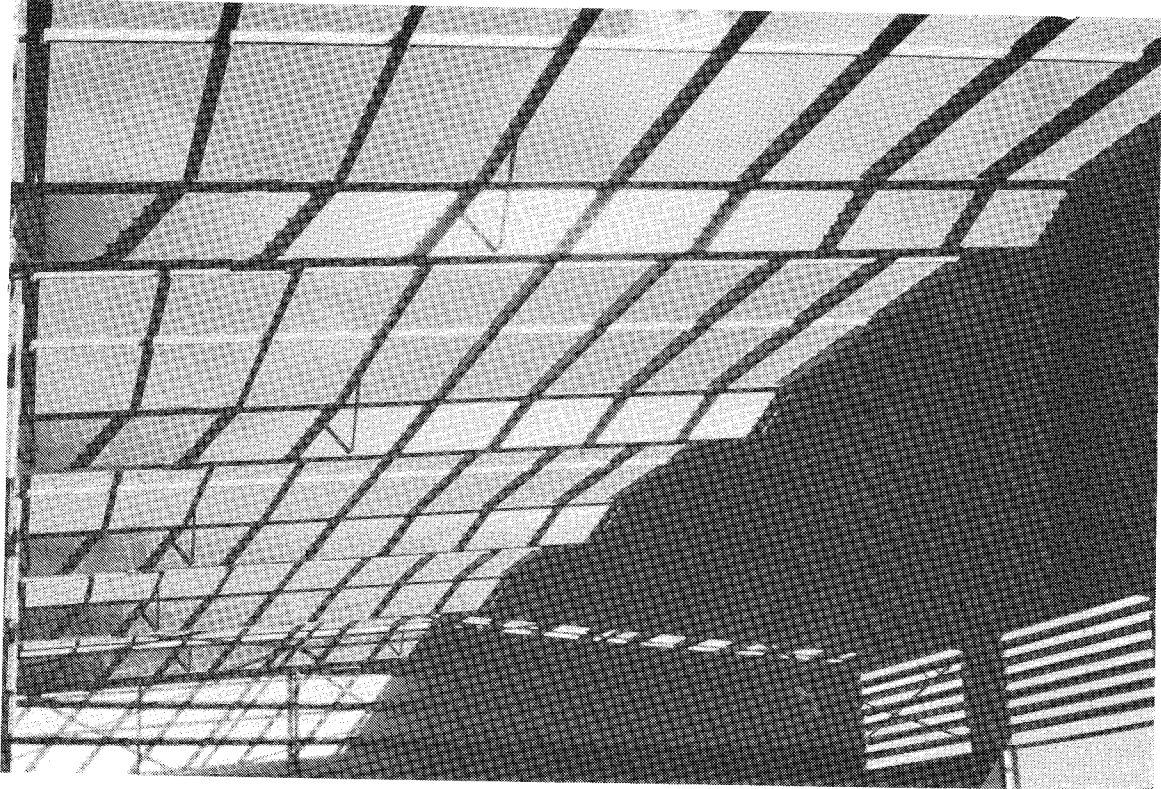

Figure 17. Secret Fixed Roofing Blown Off Building



Figure 18. Secret Fixed Roofing Blown Off Walkway

3.3 Roof Cladding Failures

Most of the roof cladding on modern buildings remained intact. This was to be expected as, over the past few years, there has been an extensive amount of testing of different profiles and fixings under simulated cyclone wind conditions. However there were some failures which brought to notice two basic concerns, secret fixing and corrosion of fasteners.

3.3.1 Secret fixed cladding

At Woree High School, in suburban Cairns, a large assembly building lost half of its roofing. There was no structural damage to the portal frames but all of the secret fixed roof sheeting was blown off one slope. The fastening clips were left attached to the battens, Figure 17.

The covered walkways between classrooms also lost some roofing, Figure 18, and therefore provided an area of easy access for inspection. There was no doubt that even some of the intact clips were not functioning correctly as the clip was not locked inside the rib profile as it should be. Figure 19 shows a clip that is not properly locked into the rib.

It is postulated that failure of the walkway roofing may have been caused by the presence of screws inserted through the flashing and each rib. As the screws would have been installed after the roofing was fitted onto the clips, they may have compressed the ribs sufficiently to allow the clips to spring out.

The bent flashing and broken screws evident in Figure 18 indicate that the roofing lifted away from the clips and rotated about the flashing, bending the screws until they broke.

The postulation for the walkways would not necessarily hold for the assembly building. The effect of overtightening screws at the ridge would hardly extend beyond the nearest adjacent batten.

The maximum wind gust recorded at Cairns airport was 33 m/s. As it is unlikely that the Woree school experienced gusts in excess of this figure the poor performance of the roof cladding must have been caused by inadequate fixing. This therefore raises the question of the suitability of secret fixed roof sheeting in cyclone prone areas. Whilst secret fixing of roof sheeting may be more pleasing architecturally and far less prone to leakage, it does not allow any visual assessment of the security of the roofing. It would be very difficult to check that all the clips on a secret fixed roof were properly engaged.

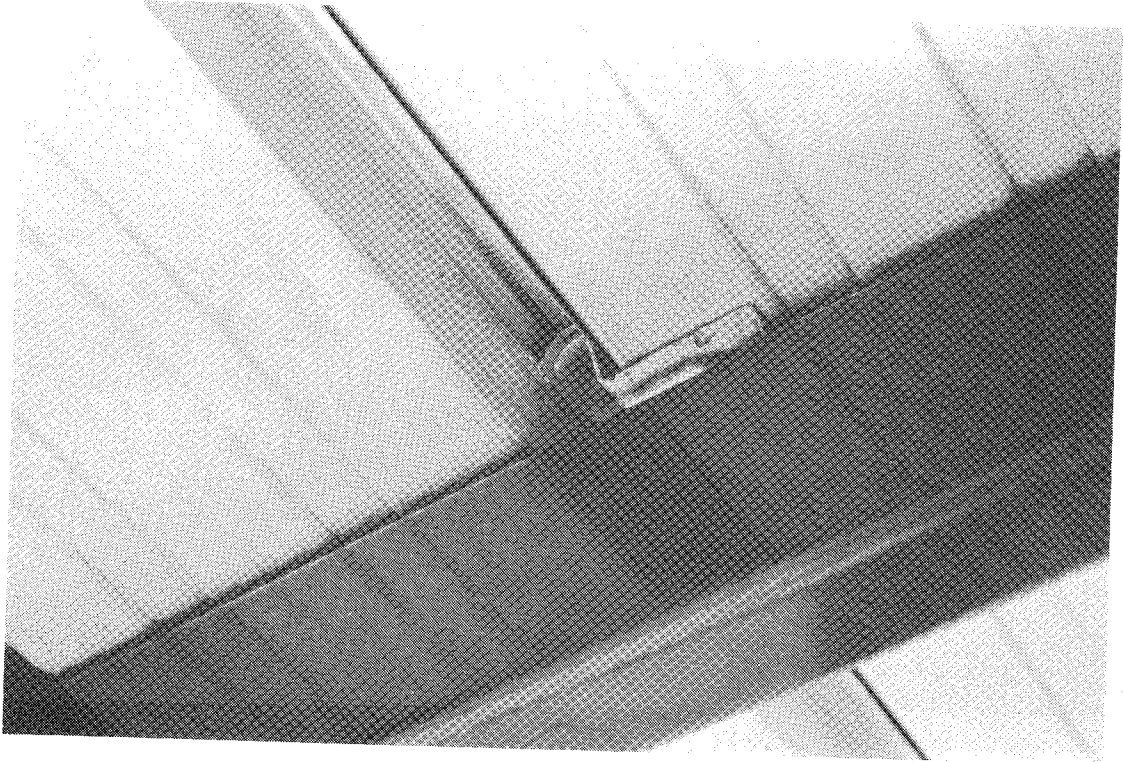

Figure 19. Roofing Clip not Properly Engaged

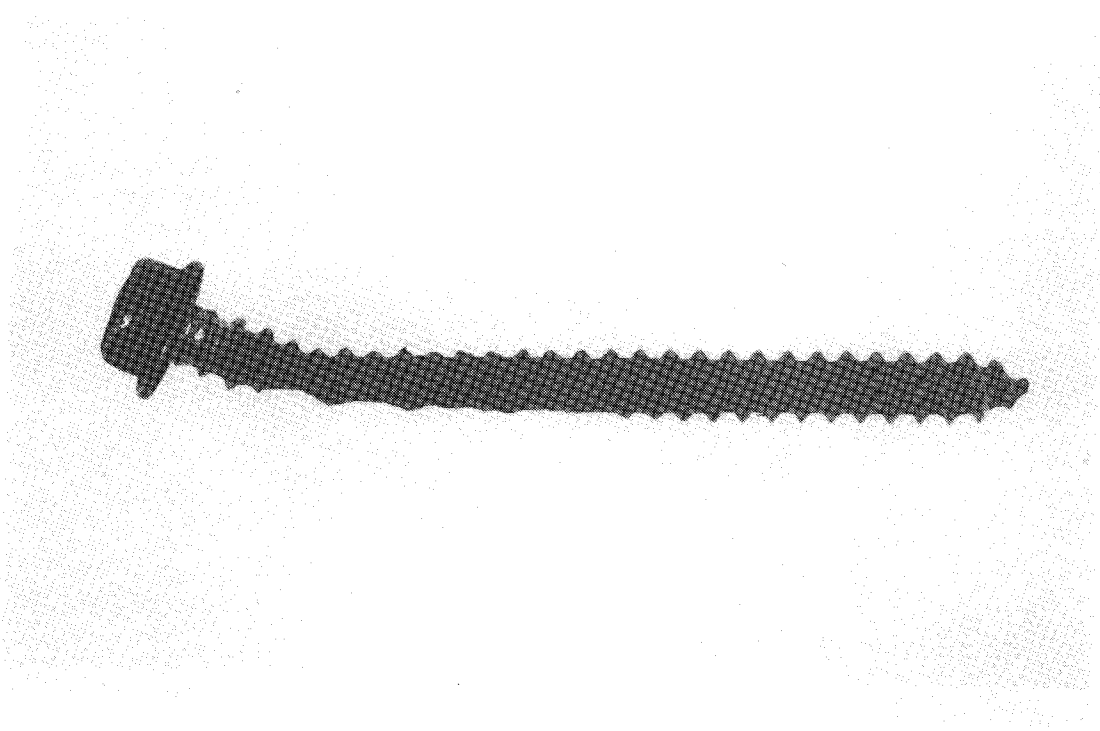

Figure 20. Severely Corroded Roofing Screw

Tests have been conducted by the Cyclone Testing Station and others to verify the strength of properly clipped roof sheeting under simulated cyclone conditions. This strength is not in question. What is being questioned is the degree of precision to which the average secret fixed roof is installed and the effect that this may have on its performance during a tropical cyclone.

3.3.2 Corrosion

The cyclone brought to notice a new concern in respect of roof security. Two separate examples of corrosion of roofing screws were discovered, one at Innisfail and the other at Atherton. The houses containing the screws were approximately two years and four years old respectively. Figure 20 shows a corroded Innisfail screw. In both cases the screws were unbranded, indicating that they were possibly "cheap imports". Australian manufacturers stamp their screw heads with a brand mark. The Atherton house had a mixture of branded and unbranded screws. It was reported that the branded screws showed no signs of corrosion.

The position of the corrosion on the screws indicates that it was probably initiated by condensation from the underside of the roof sheeting. Both Innisfail and Atherton are high rainfall areas.

3.4 Failure of Non-structural Elements

Some non-structural elements were unable to resist the wind forces imposed upon them. They include roof guttering, window awnings, doors and the like.

Many houses that were probably only a few years old had no structural damage, but lost lengths of guttering. Enquiries revealed that a relatively new gutter bracket is frequently being used by many plumbers. It enables the guttering to easily snap into position, saving installation time. Figure 21 illustrates the bracket. Although manufacturers recommend that a screw or pop rivet be used to fix the bracket to the guttering, there was no evidence of such a fastening for the cases inspected. Without that fixing the guttering was able to work free of the clips during the cyclone.

As there were many examples of this type of failure it appears that either fixings are not normally installed or that the brackets were not designed to resist uplift forces. In either case manufacturers should review the design of the bracket.

Another non-structural element that was damaged frequently was window awnings. They often comprise a series of aluminium slats attached to a frame which is mounted proud of the window. Another type consists of a screen which can be swung or rolled down to shade the window. Both types were frequently damaged. While such damage may not be considered serious and their potential hazard as a missile is relatively low, the owner is still faced with the cost of replacement.

The strength of awnings can easily be improved. One company reported a significantly better performance of its product since structural modifications were made in 1982.

Many complaints were received about water entry during the cyclone. These mainly referred to windows and doors that were "closed tight", rather than louvre windows which may be more likely to leak from wind-driven rain. The problem seems to be associated mainly with sliding windows and the inability of the bottom seal to cope with the rain and wind pressure. Apparently the normal drainage system built into the frame could not cope with the intensity of rain during Winifred. Possibly window manufacturers should investigate a better drainage system or better seals for sliding windows used in tropical cyclone areas.

There were also reports of water entry through air conditioning units or their surrounds.

Canopy structures (carports and the like) appeared to have sustained little damage. Similarly, solar panels performed well; there was no evidence of damage to them.

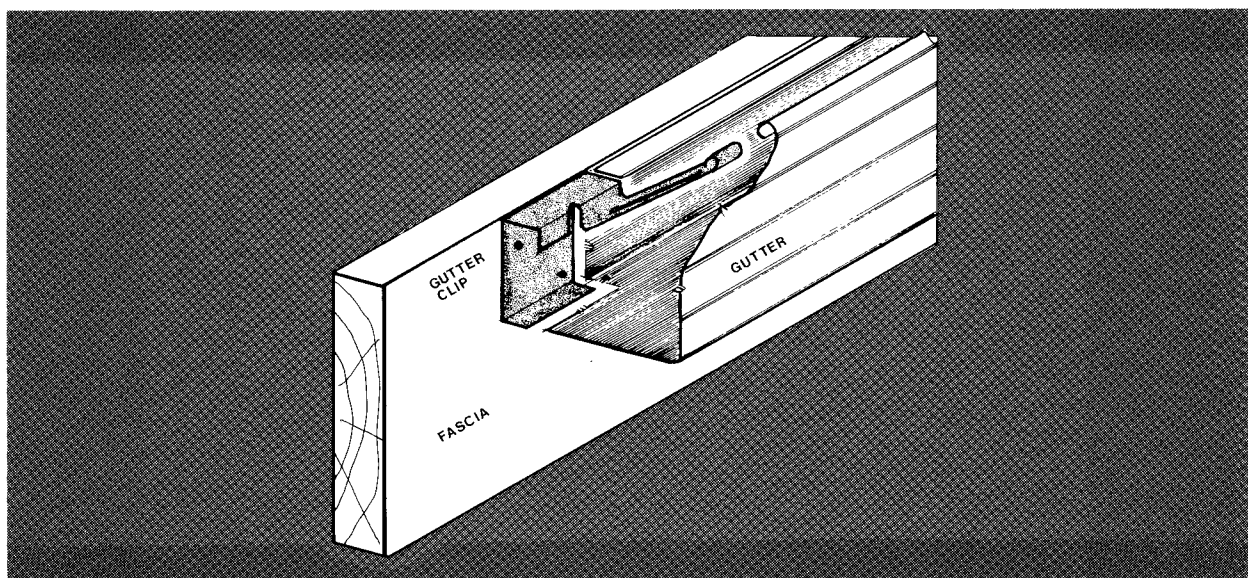

Figure 21. Gutter Bracket. Arm of Bracket Should be Fixed to Guttering

4. OLDER BUILDINGS

4.1 General

The term "older buildings" refers to those more than five years old and therefore represents the vast majority of buildings in the area affected by cyclone Winifred. It is estimated that more than 90% of buildings would be in this category, thus the potential for damage to older houses would be nearly an order of magnitude greater than the potential for damage to newer buildings. Even allowing for this ratio, the relative performance of new buildings was significantly better, as was demonstrated by the groups of houses at Kurrimine Beach. This has been attributed to the introduction of Appendix 4 to the Queensland Building Act.

4.2 Structural Failure of Domestic Buildings

4.2.1 Topographical influences

Flying Fish Point is the northern headland at the mouth of the Johnstone River. It has a narrow ridge rising steeply to about 20 metres. The short street up this ridge has nine houses, all located on the same side of the road. Topographically, it could be considered a smaller version of Coquette Point with similar hazards as the wind accelerates over the ridge.

Flying Fish Point would probably represent the greatest concentration of damage caused by cyclone Winifred. Only the two houses at the bottom of the street had minimal damage. All of the others had significant structural damage and one was totally destroyed, Figure 22. The damage included loss of roofing, loss of roof structure and some walls blown in. Figure 23 shows one of the houses that had lost some roof structure and walls.

Because of the extent of the damage and the age of the buildings, a detailed inspection was not made. The debris around the houses indicated that inadequate structural fastening and a lack of suitable bracing probably contributed to the failure of these houses. It is most likely, however, that the main factor contributing to the concentration of damage in this particular location was topography.

In current terminology, Flying Fish Point would be considered as having exposure equivalent to terrain category 1 compounded by the effects of the ridge. The design wind speed at the top of the ridge would be in excess of 70 m/s, which would require houses to be nearly three times the strength of one



Figure 22. House Destroyed on Flying Fish Point



Figure 23. Portion of Roof and Walls Blown Out

built to the provisions of Appendix 4. It was obvious that these houses, built about 30 years ago, would not have had such strength.

At Coquette Point there was a house about 15 years old located opposite the modern house described in Section 3.2.1. This older house also had the view illustrated in Figure 11, and the associated increased wind forces generated by the acceleration of the wind as it passed over the escarpment. The house was virtually destroyed by the cyclone, Figure 24. A window blew in relatively early in the event, causing the family to evacuate to the downstairs garage. Later the roof blew off and some windward walls caved in. Cyclone bolts had been incorporated in the timber framed walls but it appeared that the roof members had been nailed only.

The small township of Babinda is located in the vicinity of the gap between two major mountain ranges, Bellenden Ker to the north and Bartle Frere to the south. These topographical features undoubtedly influenced the wind regime in the Babinda area during cyclone Winifred. As previously mentioned, the township suffered considerably more damage than would have been expected from wind speeds resulting from a classical analysis of the cyclone's meteorological characteristics.

Figure 25 shows a damaged house located on the outskirts of Babinda, in category 2 terrain. It appeared that the initial failure was by the glass doors blowing in. They may have even blown out of their tracks. Subsequent to that failure the wind pressurized the inside of the house and caused the roof structure to lift and a side wall to blow out.

In this section, examples have been given of the effects on wind speed of two different types of topographical features. While the concept of increased wind speed at ridges and escarpments is generally accepted, the magnitude of the increase was usually underestimated despite specific provisions included in the Wind Loading Code. The funnelling effect of wind between two large hills is far more subtle and more likely to be overlooked. In areas such as Far North Queensland, where large topographical features are prevalent, some recognition of their potential hazard must be made.

4.2.2 Construction

Most of the structural failures of older domestic buildings could be associated with construction. Apart from the more serious examples that have already been discussed, there were a number of buildings that had damage to the roof structure only. A typical example is shown in Figure 26. In this case the roof was blown off a block of flats. The roof was of framed construction with

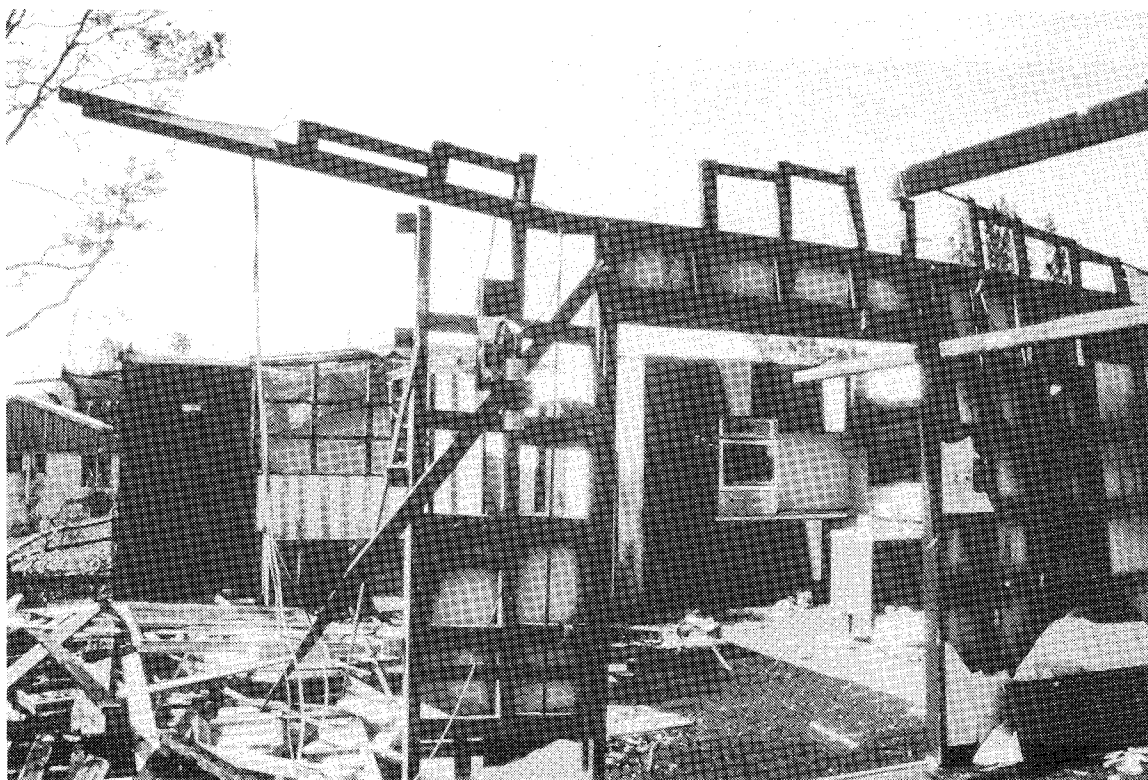

Figure 24. Older House Destroyed, Coquette Point

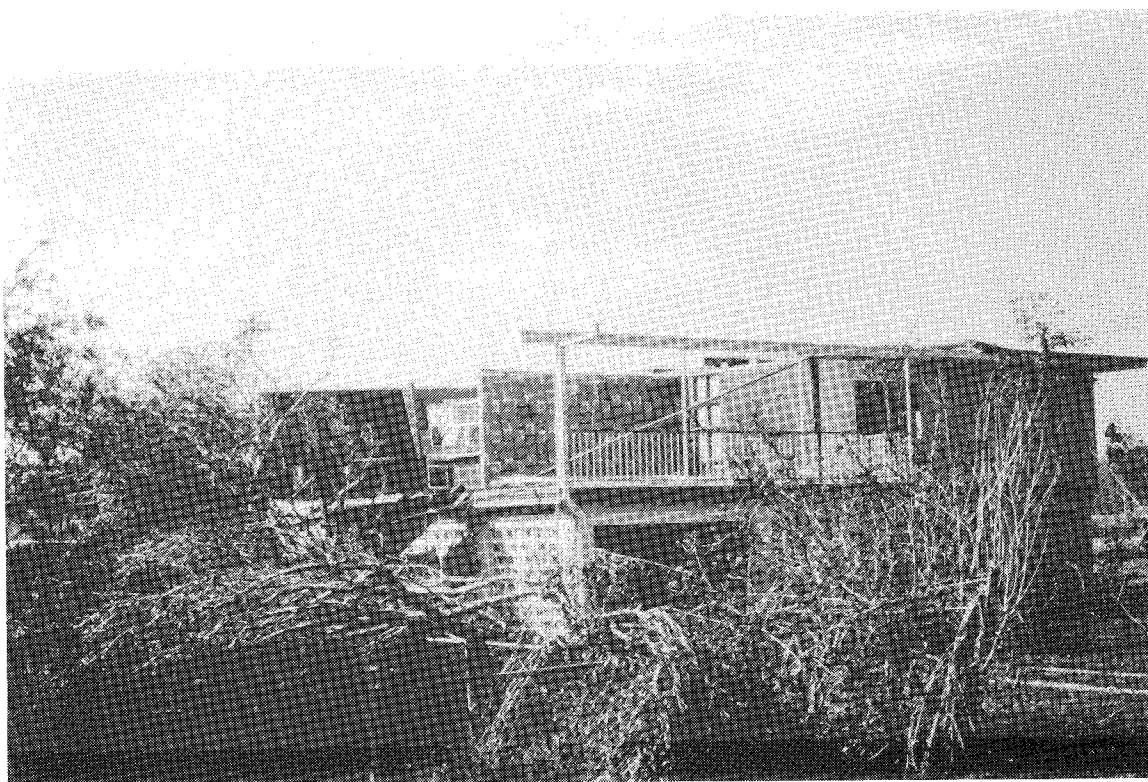

Figure 25. Portion of Roof and Walls Blown Over, Babinda



Figure 26. Roof Damage to Flats, Innisfail

cut-in rafters and separate ceiling joists. With the exception of the top plates being bolted to the brickwork the roof structure was totally nailed together. Apparently the skew nails holding rafter to top plate were inadequate to resist the uplift wind forces on the roof. Timber failure evident in the figure was probably a subsequent failure.

4.2.3 Corrosion

Two examples of structural failure due to corrosion were observed. There were probably others that went unnoticed, as corrosion often occurs on inside surfaces. Both examples were of corrosion of pipe columns. One was a picnic shelter roof on the road near Mena Creek, between Innisfail and Silkwood. The other was a carport structure at Kurrimine Beach. In this instance one support column had corroded through at the base and the others were showing corrosion near the top. Weakening of the columns by corrosion was the prime cause of failure.

4.3 Structural Failure of Other Buildings

4.3.1 School buildings

The safe performance of school buildings during tropical cyclones is very important as they are often designated by the State Emergency Service for use as places of refuge. For instance prior to Winifred making landfall the residents of Kurrimine Beach were evacuated to Silkwood State school, in case the storm surge was significant. However even that school suffered minor damage, in the form of lost roof sheeting.

Part of a classroom block at Innisfail High School had walls blown over and the roof structure blown off, Figure 27. The debris broke many windows in adjacent classroom blocks, partly penetrated a brick wall and damaged roofing on other blocks. The classroom was of timber construction with mullions at about 900 mm spacing and windows between. The walls supported roof trusses and incorporated anchor rods. Its construction, which predated current cyclone requirements, is probably typical of many other older school buildings. The school was located in classical category 2 terrain.

The failure sequence of the classroom block was not obvious, as all the debris had been cleared away. However the fact that the top plate was not intact on the remaining wall indicates that this could have been a plane of weakness. The form of construction would only allow anchor rods adjacent to door openings which would be about 4 metres apart. If the roof lifted because of this weakness the windward walls would have collapsed under the lateral pressure, due to lack of lateral bracing.

4.3.2 Agricultural or industrial buildings

No detailed assessment was made of agricultural buildings, but reports were received that older ones performed badly. Probably typical of the damage was a large poultry farm building at Bingil Bay which lost most of its roof.

It is not surprising that farm buildings were damaged, as most are in exposed locations and are constructed to minimum building standards.

Older industrial buildings performed similarly to older agricultural buildings. Some lost roofing or roof structure. There was one case, in Innisfail, of an entire concrete block wall having blown over, Figure 28. It is believed that the doors blew open during the cyclone, allowing the wind to pressurize the inside of the building and subsequently cause failure of the wall.

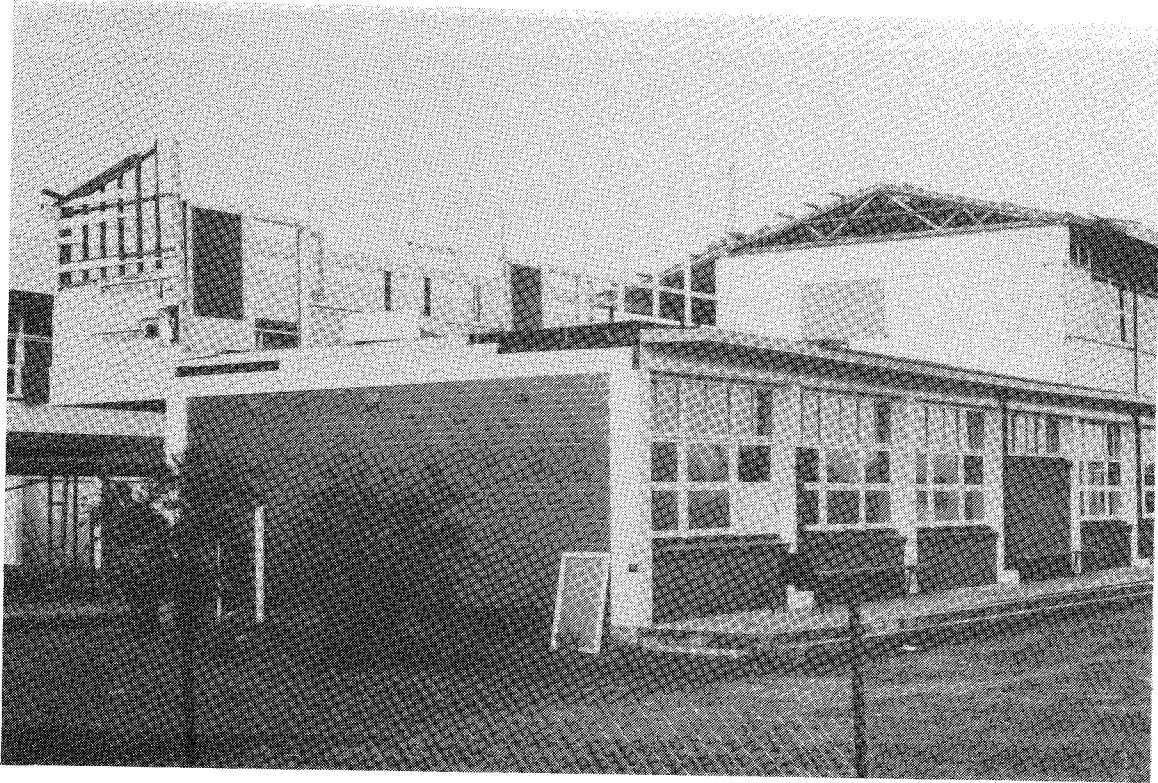

Figure 27. Damage to Classroom Block, Innisfail

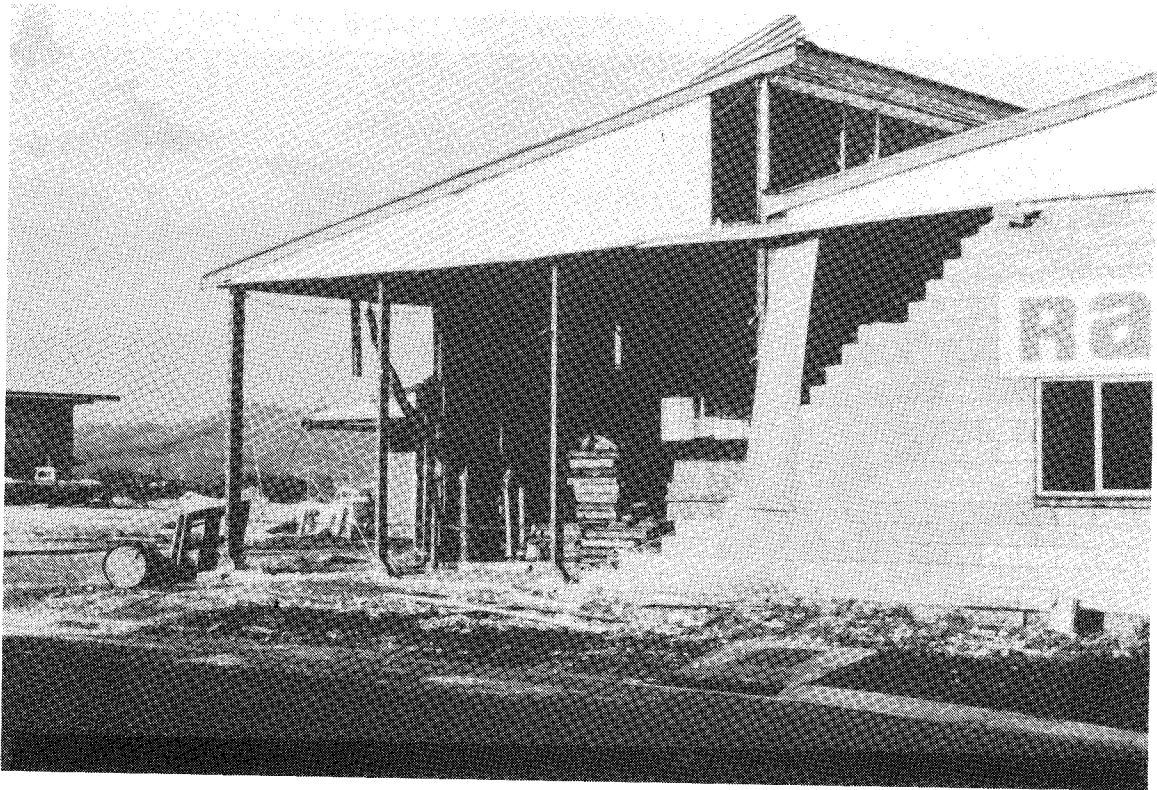

Figure 28. Factory Blockwork Wall Blown Over, Innisfail

The wall had a reinforced bond beam at the top and had some cores filled with concrete and reinforced, but these were obviously inadequate to resist the wind force. Only a few ties between the blockwork and the structural steel frame were evident. This is an example of where a little more care in construction would probably have saved the building.

4.4 Cladding Failures

There was a considerable amount of roof sheeting blown off older houses. In many cases the roofing battens were still attached, Figure 29. This is a reflection of the extensive use of power driven screws, which attach the roofing firmly to the structural member below, in upgrading the cladding attachment. It also highlights the weakness of improving cladding fastening without improving batten rafter joints, as the fastening problem is merely shifted, rather than solved, although in most cases the threshold wind speed for damage is probably increased.

Figure 31 shows an example of faulty construction which resulted in ribbed roofing being pulled over screwed cyclone washers. The fault was related to installation rather than the roofing components. As can be seen in the figure, the edge rib had no fastenings in it and there was no evidence of the sheeting having been attached to the flashing. This meant that there was excessive force acting on the first row of screws as well as a prising action caused by the unattached roofing. The rest of the roofing had been very well secured with screws and cyclone washers.

4.5 Flying Debris

The loss of roofing during the cyclone created a potential hazard from flying debris. Figure 31 shows a section of rafter having been lifted from the house in the background. Despite these missiles there was little evidence of damage to walls by flying debris. The only obvious example was at Innisfail High School, already mentioned in Section 4.3.1. There were a number of claims, and some evidence, of roofs having been hit by flying debris from a neighbouring building, but it must be concluded that the overall debris damage was small compared with the potential for damage.

Despite the forgoing, a teenage girl was seriously injured when a sheet of roofing crashed through the window of her home at Innisfail.

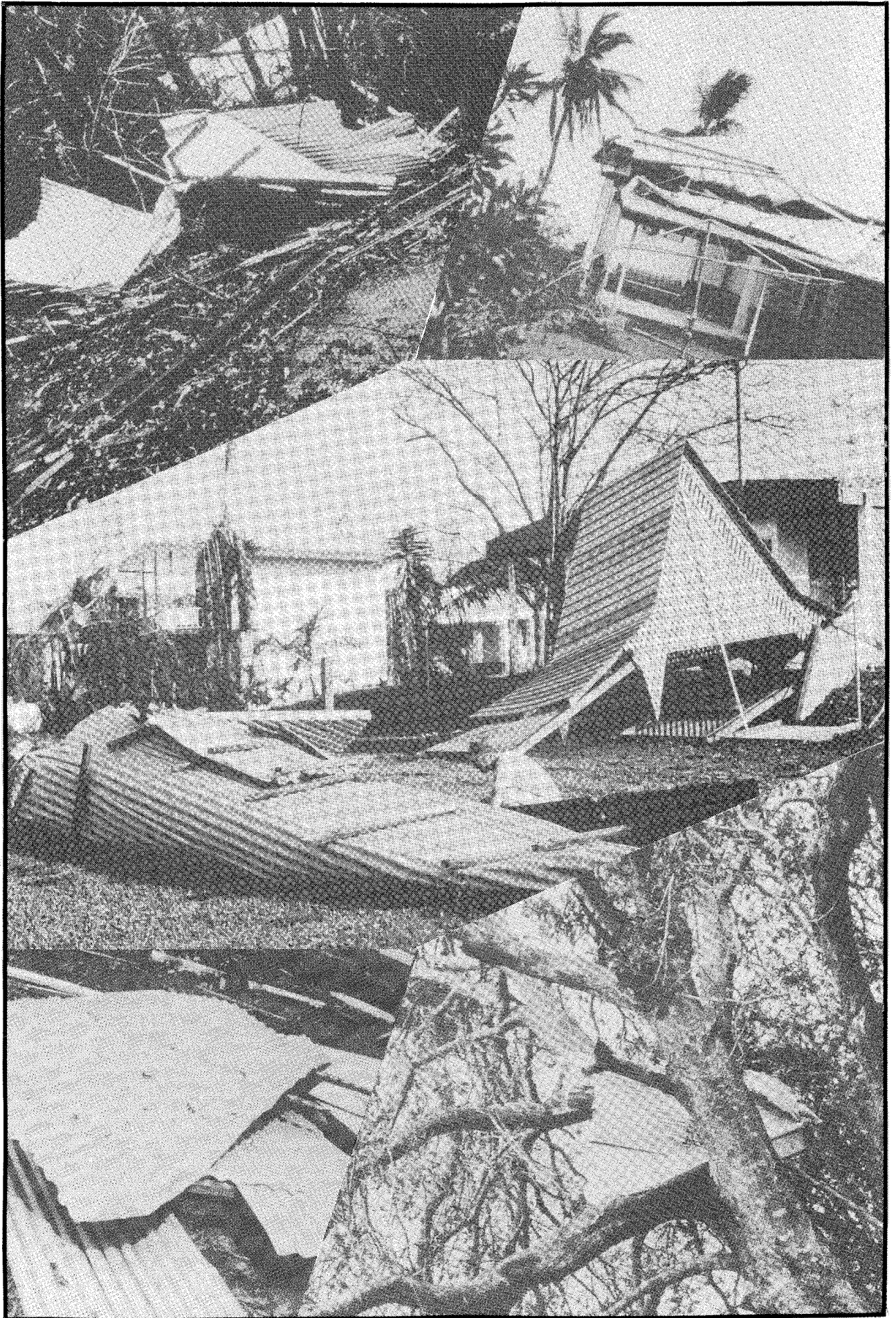

Figure 29. Roofing and Battens Blown off Buildings

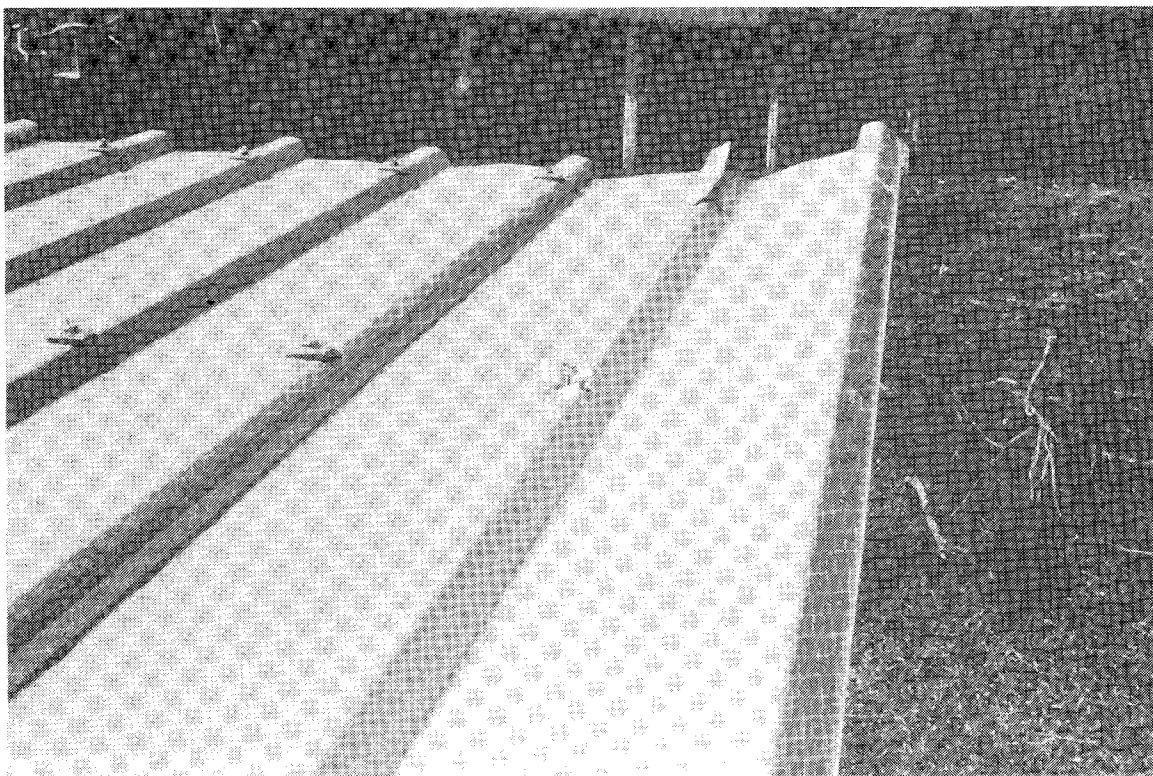

Figure 30. Faulty Construction - Lack of Fasteners in Edge Rib

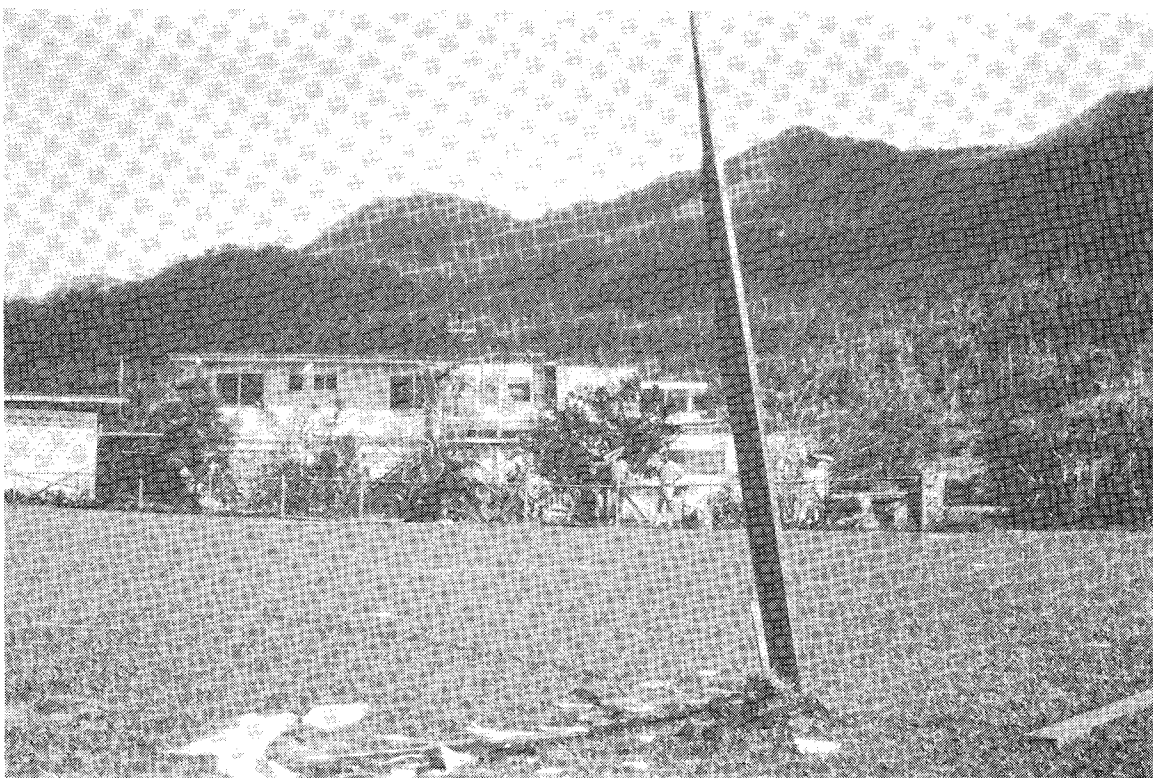

Figure 31. Broken Rafter from House in Background, Babinda

5. OTHER CONSTRUCTION

5.1 Shade Cloth Structures

There are some 70 plant nurseries in the environs of Cairns that use shade cloth structures to provide plants with filtered light conditions. The tent-like buildings use either poles or frames as the main structural elements and have cables between them, to which the knitted or woven shade cloth is attached. Most of these buildings were non-engineered on the assumption that failure would not endanger human life and the cost of repair would be small. Many of the buildings failed, despite the relatively low wind speeds experienced in the vicinity of Cairns.

There was only one shade cloth structure that had been structurally designed. It was a large marquee style building that covered approximately one hectare. The basic structure consisted of four lines of poles with cables forming catenaries between them with the shade cloth attached to the cables. It must be emphasized that the structural analysis of such a building in respect of cyclone wind forces would be very complex. The porosity of the fabric would need to be established and some estimate made of the effect of this on wind pressures. The dynamic response of the fabric to cyclone gusts would also have to be established and some assessment made as to the effect on the supporting structure.

It was not surprising therefore to see some damage to the large shade house. The uplift forces were apparently greater than anticipated and fractured the connecting piece between a pole and a guy cable. This allowed some other support poles to lift and pull their footings out of the ground. Figure 32 shows a support pole and footing that had been lifted and displaced sideways by about 1 1/2 metres. Some poles pierced the cloth as it flapped in the wind, and eventually allowed it to fall onto the plants.

The smaller and much simpler shade houses were damaged because they had absolutely no engineering input and had generally been constructed to support only the gravity loading of the shade cloth. Failures included racking of the structure, tearing of the cloth at the joins and tearing at hold down location. It is likely that many of the failures of these simple structures could have been foreseen and prevented by engineering design. The design problems associated with a series of simple frame structures supporting shade cloth are less complex than those outlined above for the tent-like structure. Simplifying assumptions based on estimations of the response of the fabric would be less critical in the design of simple framed structures.



Figure 32. Support Pole and Footing Displaced from Original Position
(at right foot)

It is believed that only the nurseryman with the engineered shade house was able to purchase insurance cover. However, losses from sun damage to plants (even when subjected to only one day's exposure to direct sunlight in some cases) were often several times the structural repair costs and have led to a greater interest in the construction of wind resistant shade cloth structures. The complexity of their behaviour makes this a challenging task for the structural engineering profession. Studies are currently being undertaken at James Cook University on the design of a basic low cost wind resistant shade cloth structure.

5.2 Caravans

There were a number of caravan parks at beach resorts in the area hit by cyclone Winifred. In general, there was little wind damage to the vans although some were damaged by falling branches or trees. The van parks were usually located in treed areas and therefore gained some protection from the wind.

There were two other aspects which probably contributed more to the performance of the vans. Firstly, at Mission Beach and Kurrimine where there were large caravan parks, the wind direction was mainly parallel to the coastline. This approach along the heavily timbered land was more favourable to the caravans than an approach directly off the sea, as it maximized the shielding obtained from the vegetation.

The other aspect was that most caravans in each park were securely anchored to concrete slabs. Turnbuckles secured the chassis to tie-down rings set in the slab. This system of securing a caravan is preferable to the use of rope over the top of the van. Ropes can cause concentrations of force on parts of the van body that were not designed to resist such forces.

6. CONCLUSIONS

1. Although cyclone Winifred resulted in extensive crop losses and serious hardship for the farming community, it cannot be considered a severe event in respect of building damage.
2. Maximum wind speeds between 50 and 55 m/s in terms of 3 second gusts at 10 m height in terrain category 2 may have been experienced in the most severely affected areas.
3. Current design criteria requires buildings in cyclone areas of Queensland to be designed for 63 m/s by working stress design which implies that failure should not occur unless wind speeds exceed at least 75 m/s. Thus buildings designed and constructed to current requirements should have performed well, and with very few exceptions they did.
4. The excellent overall performance of new houses built to the provisions of the Home Building Code suggests that the effort and expense that has been put into developing and implementing these new regulations has been justified.
5. Where structural failures occurred in buildings built under the current provisions, topography appeared to be the primary factor. There is evidence that the full consequences for wind design of siting houses in very exposed positions on the tops of ridges, hills and bluffs is not fully recognised by designers.

6. There is a need for attachments such as guttering and awnings to be required to satisfy the same structural requirements as the buildings to which they are attached.
7. The poor performance of roll-away or tilting doors needs further investigation in respect of design or installation.
8. The use of secret fixed roofing in cyclone areas must be questioned, in view of the difficulties of ensuring that it is properly installed.
9. Losses due to water entry through undamaged windows and wall airconditioning units were significant enough to raise questions about the need for more stringent requirements in this regard.
10. The performance of some school buildings was disturbing in view of their common designation as centres of refuge during a cyclone.
11. In respect of housing predating the current cyclone resistant requirements the most common type of failure was loss of roof cladding, frequently with the battens still attached. However the overall damage appears to have been less than would have been expected from past performance suggesting that improved fixing of the roof cladding has improved the resistance at moderate wind speeds. There was little evidence of damage by flying debris or of walls failing in racking.
12. Although only a few examples of failure due to corrosion were observed, cyclone Winifred highlighted this as a potential problem in the future, especially in respect of roofing screws.

7. ACKNOWLEDGEMENTS

The investigation was undertaken by the Centre for Disaster Studies at James Cook University of North Queensland in conjunction with the Department of Civil and Systems Engineering and the Department of Behavioural Sciences of the University and the James Cook Cyclone Structural Testing Station. Financial assistance for the investigation was received from the Queensland Government through the Co-ordinator General. Grateful acknowledgement is given to Dr. John Holmes from CSIRO Division of Building Research who collaborated with the authors during the investigation. The co-operation of the engineer and the Building Surveyor of Johnstone Shire Council is acknowledged, as is the co-operation of the Bureau of Meteorology and the Department of Defence in providing the meteorological data used in this paper.

8. REFERENCES

1. HOLMES, J.D. Report on Structural Damage at Burketown after Cyclone Ted 19/12/76. Wind Engineering Report 1/77, Department of Civil and Systems Engineering, James Cook University, Townsville, 1977.
2. OLIVER, J. and WALKER, G.R. Cyclone Kerry - Effects on Mackay. Disaster Investigation Report No. 2, Centre for Disaster Studies, James Cook University, Townsville, 1979.
3. HOME BUILDING CODE QUEENSLAND. Appendix 4 to the Standard Building By-Laws 1975, Queensland Government Printer.
4. GRAHAM, H.E. and NUNN, D.E. (1959). Meteorological considerations pertinent to standard project hurricanes, Atlantic and Gulf Coasts of the United States. National Hurricane Research Project Report No. 33, U.S. Department of Commerce, Washington.
5. MARTIN, G.S. (1974). Probability distributions for hurricane wind gust speeds on the Australian coast. Proceedings, Conference on Applications of Probability Theory to Structural Design, Institution of Engineers Australia, Melbourne.
6. ATKINSON, G.D. and HOLLIDAY, C.R. (1975). Tropical cyclone minimum sea level pressure - maximum sustained wind relationships for the western North Pacific. Bulletin of the American Meteorological Society, Vol. 56, No. 2.
7. GOMES, L. and VICKERY, B.J. (1976). Tropical cyclone gust speeds along the northern Australian coast. Civil Engineering Transactions, Institution of Engineers Australia, Vol. CE18, No. 2, pp. 40-48.
8. TRYGGVASON, B.V. (1979). Computer simulation of tropical cyclone wind effects for Australia. Wind Engineering Report No. 2/79, Department of Civil and Systems Engineering, James Cook University of North Queensland, Townsville.
9. GEORGIU, P.N., DAVENPORT, A.G. and VICKERY, B.J. (1983). Design wind speeds in regions dominated by tropical cyclones. Journal of Wind Engineering and Industrial Aerodynamics, Vol. 13, pp. 139-152.
10. COOK, N.J. (1985). The Designer's Guide to Wind Loading of Building Structures, Part 1, Butterworths, London.

11. MELBOURNE, W.H. Design Wind Data for Hong Kong and Surrounding Coastline. Proc. 3rd Int. Conf. on Tall Buildings, University of Hong Kong, 1984.
12. WALKER, G.R. Preliminary Report on Cyclone Winifred, Centre for Disaster Studies, James Cook University, Townsville, 1986.
13. S.A.A. Loading Code: Part 2 - Wind Forces AS1170, Part 2 - 1983.